

DOCUMENT MADE AVAILABLE UNDER THE PATENT COOPERATION TREATY (PCT)

International application number:	PCT/US2019/038084
International filing date:	20 June 2019 (20.06.2019)
Document type:	Certified copy of priority document
Document details:	Country/Office: US
	Number: 16/138,518
	Filing date: 21 September 2018 (21.09.2018)
Date of receipt at the International Bureau:	05 July 2019 (05.07.2019)

Remark: Priority document submitted or transmitted to the International Bureau in compliance with Rule 17.1(a),(b) or (b-bis)

1006931

THE UNITED STATES OF AMERICA

TO ALL TO WHOM THESE PRESENTS SHALL COME:

UNITED STATES DEPARTMENT OF COMMERCE

United States Patent and Trademark Office

July 04, 2019

THIS IS TO CERTIFY THAT ANNEXED HERETO IS A TRUE COPY FROM THE RECORDS OF THE UNITED STATES PATENT AND TRADEMARK OFFICE OF THOSE PAPERS OF THE BELOW IDENTIFIED PATENT APPLICATION THAT MET THE REQUIREMENTS TO BE GRANTED A FILING DATE.

APPLICATION NUMBER: 16/138,518

FILING DATE: *September 21, 2018*

RELATED PCT APPLICATION NUMBER: *PCT/US19/38084*

THE COUNTRY CODE AND NUMBER OF YOUR PRIORITY APPLICATION, TO BE USED FOR FILING ABROAD UNDER THE PARIS CONVENTION, IS *US16/138,518*



Certified by

Michelle M. Lee

Under Secretary of Commerce
for Intellectual Property
and Director of the United States
Patent and Trademark Office

PATENT

Practitioner's Docket No.: U 020233-5

CERTIFICATION UNDER 37 C.F.R. 1.8(a) and 1.10*
*(When using Express Mail, the Express Mail label number is mandatory;
Express Mail certification is optional.)*

I hereby certify that, on the date shown below, this correspondence is being:

MAILING

deposited with the United States Postal Service in an envelope addressed to the Commissioner for Patents, P. O. Box 1450, Alexandria, VA 22313-1450.

37 C.F.R. 1.8(a)

with sufficient postage as first class mail.

37 C.F.R. 1.10*

as "Express Mail Post Office to Addressee"
Mailing Label No. (mandatory)

TRANSMISSION

transmitted by facsimile to the Patent and
Trademark Office to (571)-273-8300

EFS-WEB

transmitted electronically

Date: September 21, 2018

/Geraldine Marti/
Signature

Geraldine Marti
(type or print name of person certifying)

* Only the date of filing (§ 1.6) will be the date used in a patent term adjustment calculation, although the date on any certificate of mailing or transmission under § 1.8 continues to be taken into account in determining timeliness. See § 1.703(f). Consider "Express Mail Post Office to Addressee" (§ 1.10) or facsimile transmission (§ 1.6(d)) for the reply to be accorded the earliest possible filing date for patent term adjustment calculations.

IN THE UNITED STATES PATENT AND TRADEMARK OFFICE

Mail Stop Patent Application
Commissioner for Patents
P. O. Box 1450
Alexandria, VA 22313-1450

NEW APPLICATION TRANSMITTAL

Transmitted herewith for filing is the patent application of inventor(s):

1. Dustin ABRAMSON
2. Derrick FU
3. Joe JOHNSON

For (title):

CRYPTOCURRENCY SYSTEM USING BODY ACTIVITY DATA

Type of Application

This new application is for a(n) (check one applicable item below):

- Original (nonprovisional).
 Design.
 Plant.

WARNING: Do not use this transmittal for a completion in the U.S. of an International Application under 35 U.S.C. 371(c)(4), unless the International Application is being filed as a divisional, continuation or continuation-in-part application.

WARNING: Do not use this transmittal for the filing of a provisional application.

NOTE: If one of the 3 items apply, then complete and attach ADDED PAGES FOR NEW APPLICATION TRANSMITTAL WHERE BENEFIT OF A PRIOR U.S. APPLICATION CLAIMED and a NOTIFICATION IN PARENT APPLICATION OF THE FILING OF THIS CONTINUATION APPLICATION.

- Divisional.
 Continuation.
 Continuation-in Part (C-I-P).

1. Benefit of Prior U.S. Application(s) (35 U.S.C. 119(e), 120, or 121)

NOTE: A nonprovisional application may claim an invention disclosed in one or more prior filed copending nonprovisional applications or copending international applications designating the United States of America. In order for a nonprovisional application to claim the benefit of a prior filed copending nonprovisional application or copending international application designating the United States of America, each prior application must name as an inventor at least one inventor named in the later filed nonprovisional application and disclose the named inventor's invention claimed in at least one claim of the later filed nonprovisional application in the manner provided by the first paragraph of 35 U.S.C. Section 112. Each prior application must also be:

- (i) An international application entitled to a filing date in accordance with PCT Article 11 and designating the United States of America; or
(ii) Complete as set forth in Section 1.51(b); or
(iii) Entitled to a filing date as set forth in Section 1.53(b) or Section 1.53(d) and include the basic filing fee set forth in Section 1.16; or
(iv) Entitled to a filing date as set forth in Section 1.53(b) and have paid therein the processing and retention fee set forth in Section 1.21(l) within the time period set forth in Section 1.53(f).

37 C.F.R. Section 1.78(a)(1).

WARNING: If an application claims the benefit of the filing date of an earlier filed application under 35 U.S.C. §§120, 121 or 365(c), the 20-year term of that application will be based upon the filing date of the earliest U.S. application that the application makes reference to under 35 U.S.C. §§ 120, 121 or 365(c). (35 U.S.C. 154(a)(2) does not take into account, for the determination of the patent term, any application on which priority is claimed under 35 U.S.C. §§ 119, 365(a) or 365(b).) For a C-I-P application, applicant should review whether any claim in the patent that will issue is supported by an earlier application and, if not, the applicant should consider canceling the reference to the earlier filed application. The term of a patent is not based on a claim-by-claim approach. See Notice of April 14, 1995, 60 Fed. Reg. 20,195, at 20,205.

WARNING: 37 C.F.R. ' 1.78(a)(2) deals with the time in which the claim for the benefit of an earlier filing date must be made and states:

"(2)(i) Except for a continued prosecution application filed under ' 1.53(d), any nonprovisional application or international application designating the United States of America claiming the benefit of one or more prior-filed copending nonprovisional applications or international applications designating the United States of America must contain or be amended to contain a reference to each such prior-filed application, identifying it by application number (consisting of the series code and serial number) or international application number and international filing date and indicating the relationship of the applications. Cross references to other related applications may be made when appropriate (see ' 1.14).

(ii) This reference must be submitted during the pendency of the later-filed application. If the later-filed application is an application filed under 35 U.S.C. 111(a), this reference must also be submitted within the later of four months from the actual filing date of the later-filed application or sixteen months from the filing date of the prior-filed application. If the later-filed application is a nonprovisional application which entered the national stage from an international application after compliance with 35 U.S.C. 371, this reference must also be submitted within the later of four months from the date on which the national stage commenced under 35 U.S.C. 371(b) or (i) in the later-filed international application sixteen months from the filing date of the prior-filed application. These time periods are not extendable. Except as provided in paragraph (e)(3) of this section, the failure to timely submit the reference required by 35 U.S.C. 120 and paragraph (a)(2)(i) of this section is considered a waiver of any benefit under 35 U.S.C. 120, 121, or 365(c) to such prior-filed application. The time periods in this paragraph do not apply if the later-filed application is:

- (A) An application for a design patent;
- (B) An application filed under 35 U.S.C. 111(a) before November 29, 2000; or
- (C) A nonprovisional application which entered the national stage after compliance with 35 U.S.C. 371 from an international application filed under 35 U.S.C. 363 before November 29, 2000.

(iii) If the later-filed application is a nonprovisional application, the reference required by this paragraph must be included in an application data sheet (§ 1.76), or the specification must contain or be amended to contain such reference in the first sentence following the title.

(iv) The request for a continued prosecution application under § 1.53(d) is the specific reference required by 35 U.S.C. 120 to the prior-filed application. The identification of an application by application number under this section is the identification of every application assigned that application number necessary for a specific reference required by 35 U.S.C. 120 to every such application assigned that application number."

NOTE: If the new application being transmitted is a divisional, continuation or a continuation-in-part of a parent case, or where the parent case is an International Application which designated the U.S., or benefit of a prior provisional application is claimed, then check the following item and complete and attach ADDED PAGES FOR NEW APPLICATION TRANSMITTAL WHERE BENEFIT OF PRIOR U.S. APPLICATION(S) CLAIMED.

- The new application being transmitted claims the benefit of prior U.S. application(s) and enclosed are ADDED PAGES FOR NEW APPLICATION TRANSMITTAL WHERE BENEFIT OF PRIOR U.S. APPLICATION(S) CLAIMED.

2. Papers Enclosed

A. Required For Filing Date Under 37 C.F.R. Section 1.53(b) (Regular) or 37 C.F.R. 1.153 (Design) Application

- Application Data Sheet
- 20 Pages of Specification
- 4 Pages of Claims
- 8 Sheets of Drawing

WARNING: DO NOT submit original drawings. A high quality copy of the drawings should be supplied when filing a patent application. The drawings that are submitted to the Office must be on strong, white, smooth, and non-shiny paper and meet the standards according to Section 1.84. If corrections to the drawings are necessary, they should be made to the original drawing and a high-quality copy of the corrected original drawing then submitted to the Office. Only one copy is required or desired. For comments on proposed then-new 37 C.F.R. 1.84, see Notice of March 9, 1988. (1990 O.G. 57-62).

NOTE: "Identification of drawings. Identifying indicia, if provided, should include the title of the invention, inventor's name and application number, or docket number (if any) if an application number has not been assigned to the application. If this information is provided, it must be placed on the front of each sheet and centered within the top margin."

(complete the following, if applicable)

- The enclosed drawing(s) are photograph(s).

NOTE: 37 C.F.R. 1.84

"(b) Photographs.

"(1) Black and white. Photographs, including photocopies of photographs, are not ordinarily permitted in utility and design patent applications. The Office will accept photographs in utility and design patent applications, however, if photographs are the only practicable medium for illustrating the claimed invention. For example, photographs, or photomicrographs of electrophoresis gels, blots (e.g., immunological, western, Southern and northern), auto radiographs, cell cultures (stained and unstained), histological tissue cross sections (stained and unstained), animals, plants, in vivo imaging, thin layer chromatography plates, crystalline structures, and in a design patent application, ornamental effects, are acceptable. If the subject matter of the application admits of illustration by a drawing, the examiner may require a drawing in place of the photograph. The photographs must be of sufficient quality so that all details in the photographs are reproducible in the printed patent.

"(2) Color photographs. Color photographs will be accepted in utility and design patent applications if the conditions for accepting color drawings and black and white photographs have been satisfied. See paragraphs (a)(2) and (b)(1) of this section "

- The enclosed drawing(s) are in color. Three (3) sets of color drawings and a "PETITION TO ACCEPT COLOR DRAWING(S)" are attached. 37 C.F.R. §§1.84(a)(2) and 1.84(b).

NOTE: 37 C.F.R. 1.84(a)

"(2) Color. On rare occasions color drawings may be necessary as the only practical medium by which to disclose the subject matter sought to be patented in a utility or design patent application or the subject matter of a statutory invention registration. The color drawings must be of sufficient quality such that all details in the drawings are reproducible in black and white in the printed patent. Color drawings are not permitted in international applications (see PCT Rule 11.13), or in an application, or copy thereof, submitted under the Office electronic filing system. The Office will accept color drawings in utility or design patent applications and statutory invention registrations only after granting a petition filed under this paragraph explaining why the color drawings are necessary. Any such petition must include the following:

- (i) The fee set forth in § 1.17(h);*
- (ii) Three (3) sets of color drawings;*
- (iii) A black and white photocopy that accurately depicts, to the extent possible, the subject matter shown in the color drawing; and*
- (iv) An amendment to the specification to insert (unless the specification contains or has been previously amended to contain) the following language as the first paragraph of the brief description of the drawings:*

"The patent or application file contains at least one drawing executed in color. Copies of this patent or patent application publication with color drawing(s) will be provided by the Office upon request and payment of the necessary fee."

- formal
 informal

B. Other Papers Enclosed

- ___ Declaration
- 1 Pages of Abstract
- ___ Other
- ___ Transmittal for Power of Attorney including Power of Attorney

3. Additional papers enclosed

- Preliminary Amendment
- Information Disclosure Statement (37 CFR 1.98)

WARNING: *In order to ensure consideration of information previously submitted but which has not been considered in the parent application, an applicant must resubmit the information, complying with 37 C.F.R. § 1.97 and 37 C.F.R. § 1.98, in the continuing application filed under 37 C.F.R. § 1.53(b). See § 609B(3), M.P.E.P., 7th Edition, Rev. 1.*

- Form PTO-1449
- Citations
- Declaration of Biological Deposit
- Submission of "Sequence Listing," computer readable copy and/or amendment pertaining thereto for biotechnology invention containing nucleotide and/or amino acid sequence.
- Authorization of Attorney(s) to Accept and Follow Instructions from Representative
- Special Comments
- Request for Nonpublication of Application
- Other

4. Declaration or Oath

NOTE: *A newly executed declaration is not required in a continuation or divisional application provided the prior nonprovisional application contained a declaration as required, the application being filed is by all or fewer than all the inventors named in the prior application, there is no new matter in the application being filed, and a copy of the executed declaration filed in the prior application (showing the signature or an indication thereon that it was signed) is submitted. The copy must be accompanied by a statement requesting deletion of the names of person(s) who are not inventors of the application being filed. If the declaration in the prior application was filed under Section 1.47 then a copy of that declaration must be filed accompanied by a copy of the decision granting Section 1.47 status or, if a nonsigning person under Section 1.47 has subsequently joined in a prior application, then a copy of the subsequently executed declaration must be filed. See 37 C.F.R. Section 1.63(d)(1)-(3).*

NOTE: *A declaration filed to complete an application must be executed, identify the specification to which it is directed, identify each inventor by full name, including the family name, and at least one given name without abbreviation together with any other given name or initial, and the residence, post office address and country of citizenship of each inventor, and state whether the inventor is a sole or joint inventor. 37 C.F.R. Section 1.63(a)(1)-(4).*

NOTE: *The inventorship of a nonprovisional application is that inventorship set forth in the oath or declaration as prescribed by Section 1.62, except as provided for in Section 1.53(d)(4) and Section 1.63(d). If an oath or declaration as prescribed by Section 1.63 is not filed during the pendency of a nonprovisional application, the inventorship is that inventorship set forth in the application papers filed pursuant to Section 1.53(b), unless a petition under this paragraph accompanied by the fee set forth in Section 1.17(l) is filed supplying or changing the name or names of the inventor or inventors. 37 C.F.R. Section 1.41(e)(1).*

- Enclosed

Executed by (check all applicable boxes)

- inventors.
- legal representative of inventor(s). 37 C.F.R. Section 1.42 or 1.43.

joint inventor or person showing a proprietary interest on behalf of inventor who refused to sign or cannot be reached.

This is the petition required by 37 C.F.R. 1.47 and the statement required by 37 C.F.R. 1.47 is also attached. See item 13 below for fee.

Not Enclosed.

NOTE: Where the filing is a completion in the U.S. of an International Application, or where the completion of the U.S. application contains subject matter in addition to the International Application, the application may be treated as a continuation or continuation-in-part, as the case may be, utilizing ADDED PAGE FOR NEW APPLICATION TRANSMITTAL WHERE BENEFIT OF PRIOR U.S. APPLICATION CLAIMED.

Application is made by a person authorized under 37 C.F.R. 1.41(c) on behalf of all the above named inventor(s).

Showing that the filing is authorized. (Not required unless called into question. 37 C.F.R. 1.41(d).)

5. Inventorship Statement

WARNING: If the named inventors are each not the inventors of all the claims an explanation, including the ownership of various claims at the time the last claimed invention was made, should be submitted.

The inventorship for all the claims in this application are:

The same.

OR

Not the same. An explanation, including the ownership of the various claims at the time the last claimed invention was made.

is submitted.

will be submitted.

6. Language

NOTE: An application including a signed oath or declaration may be filed in a language other than English. An English translation of the non-English language application and the processing fee of \$130.00 required by 37 C.F.R. Section 1.17(k) is required to be filed with the application, or within such time as may be set by the Office. 37 C.F.R. Section 1.52(d).

English

Non-English

The attached translation includes a statement that the translation is accurate. 37 C.F.R. 1.52(d).

7. Assignment

An assignment of the invention to

MICROSOFT TECHNOLOGY LICENSING, LLC

- is attached. A separate "COVER SHEET FOR ASSIGNMENT (DOCUMENT) ACCOMPANYING NEW PATENT APPLICATION" or FORM PTO 1595 is also attached.
- will follow.
- has been recorded at Reel _____, Frame _____ on _____.

NOTE: "If an assignment is submitted with a new application, send two separate letters - one for the application and one for the assignment." Notice of May 4, 1990 (1114 O.G. 77-79).

WARNING: A newly executed "STATEMENT UNDER 37 C.F.R. 3.73(b)" must be filed when a continuation-in-part application is filed by an assignee. Notice of April 30, 1993. 1150 O.G. 62-64.

8. **Certified Copy**

Certified copy(ies) of application(s)

Country	Appln. No.	Filed
from which priority is claimed		

- is (are) attached.
- A Request to Retrieve Electronic Priority Application is attached.
- was filed in parent application _____.
- is (are) attached.
- will follow

NOTE: 37 C.F.R. §1.55. Claim for foreign priority.

(a) ***

(1)(i) In an original application filed under 35 U.S.C. 111(a), the claim for priority must be presented during the pendency of the application, and within the later of four months from the actual filing date of the application or sixteen months from the filing date of the prior foreign application. This time period is not extendable. The claim must identify the foreign application for which priority is claimed, as well as any foreign application for the same subject matter and having a filing date before that of the application for which priority is claimed, by specifying the application number, country (or intellectual property authority), day, month, and year of its filing. The time periods in this paragraph do not apply in an application under 35 U.S.C. 111(a) if the application is:

- (A) A design application; or
- (B) An application filed before November 29, 2000.

(C) Unless such claim is accepted in accordance with the provisions of this paragraph, any claim for priority under 35 U.S.C. 119(a)-(d) or 365(a) not presented within the time period provided by paragraph (a) of this section is considered to have been waived. If a claim for priority under 35 U.S.C. 119(a)-(d) or 365(a) is presented after the time period provided by paragraph (a) of this section, the claim may be accepted if the claim identifying the prior foreign application by specifying its application number, country (or intellectual property authority), and the day, month, and year of its filing was unintentionally delayed. A petition to accept a delayed claim for priority under 35 U.S.C. 119(a)-(d) or 365(a) must be accompanied by:

(1) The claim under 35 U.S.C. 119(a)-(d) or 365(a) and this section to the prior foreign application, unless previously submitted;

(2) The surcharge set forth in § 1.17(f); and

(3) A statement that the entire delay between the date the claim was due under paragraph (a)(1) of this section and the date of the claim was filed was intentional. The Commissioner may require additional information where there is a question whether the delay was intentional."

NOTE: 37 C.F.R. § 1.63 Oath or declaration.

"(a) An oath or declaration filed under § 1.51(b)(2) as a part of a nonprovisional application must:

(c) Unless such information is supplied on an application data sheet in accordance with § 1.76, the oath or declaration must also identify:

(2) An foreign application for patent (or inventor's certificate) for which a claim for priority is made pursuant to § 1.55, and any foreign application having a filing date before that of the application on which priority is claimed, by specifying the application number, country, day, month and year of its filing."

The foreign application forming the basis for the claim for priority must be referred to in the oath or declaration 37 C.F.R. § 1.55(a) and 1.63.

NOTE: This item is for any foreign priority for which the application being filed directly relates. IF any parent U.S. application or international Application form which this application claims benefit under 35 U.S.C. § 120 is itself entitled to priority from a prior foreign application, then complete item 18 on the ADDED PAGES FOR NEW APPLICATION TRANSMITTAL WHERE BENEFIT OF PRIOR U.S. APPLICATION(S) CLAIMED.

9. Fee Calculation (37 CFR 1.16)

- A. Regular Application Filing Fees \$1,720.00
 B. Additional fee for specification and drawings filed in paper over 100 sheets (excluding sequence listing or computer program listing filed in electronic medium). The fee is \$320 for each additional 50 sheets of paper or fraction thereof \$0.00

CLAIMS AS FILED						
Claims	Number Filed	Number Extra			Rate	
Total Claims (37 CFR Section 1.16(c))	20	- 20 =		x	\$100.00	
Independent Claims (37 CFR Section 1.16(b))	3	- 3 =		x	\$460.00	\$
Multiple Dependent Claim(s), if any (37 CFR Section 1.16(d))					\$820.00	0.00

- Amendment canceling extra claims is enclosed or above.
 Amendment deleting multiple-dependencies is enclosed.
 Fee for extra claims is not being paid at this time.

Note: If the fees for extra claims are not paid on filing they must be paid or the claims canceled by amendment, prior to the expiration of the time period set for response by the Patent and Trademark Office in any notice of fee Deficiency. 37 C.F.R. Section 1.16(d).

Fee Calculation \$ 1,720.00

- B. Design application
(\$760.00--37 C.F.R. Section 1.16(f))
- Fee Calculation \$ 0.00
- C. Plant application
(\$830.00--37 C.F.R. Section 1.16(g))
- Fee Calculation \$ 0.00

10. Small Entity Statement(s)

- Statement(s) or Written Assertion(s) that this is a filing by a small entity under 37 C.F.R. 1.9 and 1.27 is(are) attached.
- Applicant hereby asserts small entity status by paying the small filing fee.

NOTE: 37 C.F.R. §1.27(c) deals with the assertion of small entity status, whether by a written specific declaration thereof or by payment as a small entity of the basic filing fee or the fee for the entry into the national phase and states:

"(c) Assertion of small entity status. Any party (person, small business concern or nonprofit organization) should make a determination, pursuant to paragraph (f) of this section, of entitlement to be accorded small entity status based on the definitions set forth in paragraph (a) of this section, and must, in order to establish small entity status for the purpose of paying small entity fees, actually make an assertion of entitlement to small entity status, in the manner set forth in paragraphs (c)(1) or (c)(3) of this section, in the application/patent in which such small entity fees are to be paid.

- (1) Assertion by writing. Small entity status may be established by a written assertion of entitlement to small entity status. A written assertion must:
- (i) Be clearly identifiable;
 - (ii) Be signed (see paragraph (c)(20) of this section); and
 - (iii) Convey the concept of entitlement to small entity status, such as by stating that applicant is a small entity, or that small entity status is entitled to be asserted for the application or patent. While no specific words or wording are required to assert small entity status, the intent to assert small entity status must be clearly indicated in order to comply with the assertion requirement.
- (2) Parties who can sign and file the written assertion. The written assertion can be signed by:
- (i) One of the parties identified in § 1.33(b) (e.g., an attorney or agent registered with the Office), 3.73(b) of this chapter notwithstanding, who can also file the written assertion;
 - (ii) At least one of the individuals identified as an inventor (even though a § 1.63 executed oath or declaration has not been submitted), not withstanding § 1.33(b)(4), who can also file the written assertion pursuant to the exception under § 1.33(b) of this part; or
 - (iii) An assignee of an undivided part interest, notwithstanding §§ 1.33(b)(3) and 3.73(b) of this chapter, but the partial assignee cannot file the assertion without resort to a party identified under § 1.33(b) of this part.
- (3) Assertion by payment of the small entity basic filing or basic national fee. The payment, by any party, of the exact amount of one of the small entity basic filing fees set forth in §§ 1.16(a), (f), (g), (h), or (k), or one of the small entity basic national fees set forth in §§ 1.492(a)(1), (a)(2), (a)(3), (a)(4), or (a)(5), will be treated as a written assertion of entitlement to small entity status even if the type of basic filing or basic national fee is inadvertently selected in error.
- (i) If the Office accords small entity status based on payment of a small entity basic filing or basic national fee under paragraph (c)(3) of this section that is not applicable to that application, any balance of the small entity fee that is applicable to that application will be due along with the appropriate surcharge set forth in § 1.16(e), or § 1.16(f).
 - (ii) The payment of any small entity fee other than those set forth in paragraph (c)(3) of this section (whether in the exact fee amount or not) will not be

treated as a written assertion of entitlement to small entity status and will not be sufficient to establish small entity status in an application or a patent."

WARNING: 37 C.F.R. § 1.27(c)(4): "Assertion required in related, continuing, and reissue applications. Status as a small entity must be specifically established by an assertion in each related, continuing and reissue application in which status is appropriate and desired. Status as a small entity in one application or patent does not affect the status of any other application or patent, regardless of the relationship of the applications or patents. The refiling of an application under § 1.53 as a continuation, divisional, or continuation-in-part application (including a continued prosecution application under § 1.53(d)), or the filing of a reissue application, requires a new assertion as to continued entitlement to small entity status for the continuing or reissue application."

WARNING: "Small entity status must not be established when the person or persons signing the . . . statement can unequivocally make the required self-certification." M.P.E.P. Section 509.03, 6th ed., rev. 2, July 1996 (emphasis added).

(complete the following, if applicable)

Status as a small entity was claimed in prior application _____, filed on _____ from which benefit is being claimed for this application under:

35 U.S.C. section 119(e) – provisional,
 120 – continuation,
 121 – divisional,
 365(c) – PCT,

and which status as a small entity is still proper and desired.

A copy of the statement or written assertion in the prior application is included.

Filing Fee Calculation (50% of A, B or C above) \$ _____

NOTE: A refund based on establishment of small entity status, of a portion of fees timely paid in full prior to establishing status as a small entity may only be obtained if an assertion under § 1.27(c) and a request for a refund of the excess amount are filed within three months of the date of the timely payment of the full fee. The three-month time period is not extendable under § 1.136. 37 C.F.R. § 1.28(a).

11. Request for International-Type Search (37 C.F.R. Section 1.104(d)) (Complete, if applicable)

Please prepare an international-type search report for this application at the time when national examination on the merits takes place.

12. Fee Payment Being Made At This Time

Not Enclosed

No filing fee is to be paid at this time and any and all prior fee authorizations are revoked.
(This and the surcharge required by 37 CFR Section 1.16(e) can be paid subsequently.)

Enclosed

Filing fee \$ 1,720.00

- | | | |
|-------------------------------------|---|------------------|
| <input type="checkbox"/> | Recording assignment
(\$40.00; 37 CFR Section 1.21(h)) (See attached
"COVER SHEET FOR ASSIGNMENT
ACCOMPANYING NEW APPLICATION.") | \$ _____ |
| <input type="checkbox"/> | Petition and fee for filing by other than all the
inventors or person on behalf of the inventor where
inventor refused to sign or cannot be reached
(\$200.00; 37 CFR Sections 1.47 and 1.17(i)) | \$ _____ |
| <input type="checkbox"/> | For processing an application with a specification in
a non-English language
(\$130.00; 37 CFR Sections 1.52(d) and 1.17(k)) | \$ _____ |
| <input type="checkbox"/> | Processing and retention fee
(\$130.00; 37 CFR Sections 1.53(d) and 1.21(l)) | \$ _____ |
| <input type="checkbox"/> | Fee for international-type search report
(\$40.00; 37 CFR Section 1.21(e)) | \$ _____ |
| | Surcharge fees | |
| <input checked="" type="checkbox"/> | late payment of filing fee and/or late filing of
original declaration or oath
(37 C.F.R. Section 1.16(e)--\$160; small entity---
\$80) | \$ 160.00 |

NOTE: Even where a facsimile declaration or oath signed by the inventor(s) was part of the originally filed papers, the surcharge fee is required.

NOTE: If both the filing fee and declaration or oath were missing from the original papers, the Office practice under 37 C.F.R. Section 1.16(e) is that only one surcharge fee need be paid whether the later filed oath or declaration and/or the filing fee are submitted afterwards at the same time or at different times.

NOTE: 37 C.F.R. Section 1.21(l) establishes a fee for processing and retaining any application that is abandoned for failing to complete the application pursuant to 37 C.F.R. Section 1.53(f) and this, as well as the changes to 37 C.F.R. Section 1.53 and 1.78(a)(1), indicate that in order to obtain the benefit of a prior U.S. application, either the basic filing fee must be paid, or the processing and retention fee of Section 1.21(l) must be paid, within 1 year from notification under Section 53(f).

Total fees enclosed \$ 1,880.00

13. Method of Payment of Fees

- Check in the amount of \$ 0.00.
- Charge Account No. 12-0425 in the amount of \$ 1,880.00

14. Authorization to Charge Additional Fees

WARNING: If no fees are to be paid on filing, the following items should not be completed.

WARNING: Accurately count claims, especially multiple dependent claims, to avoid unexpected high charges, if extra claim charges are authorized.

- The Commissioner is hereby authorized to charge the following additional fees by this paper and during the entire pendency of this application to Account No. 12-0425.
- 37 CFR Section 1.16(a), (f) or (g) (filing fees)
- 37 CFR Section 1.16(b), (c) and (d) (presentation of extra claims)

NOTE: Because additional fees for excess or multiple dependent claims not paid on filing or on later presentation must only be paid or these claims canceled by amendment prior to the expiration of the time period set for response by the PTO in any notice of fee deficiency (37 C.F.R. Section 1.16(d)), it might be best not to authorize the PTO to charge additional claim fees, except possibly when dealing with amendments after final action.

- 37 CFR Section 1.16(e) (surcharge for filing the basic filing fee and/or declaration on a date later than the filing date of the application)
- 37 CFR Section 1.17(a)(1)-(5) (extension fees pursuant to Section 1.136(a).
- 37 CFR Section 1.17(a)(1)-(5) (application processing fees)

NOTE: "A written request may be submitted in an application that is an authorization to treat any concurrent or future reply, requiring a petition for an extension of time under this paragraph for its timely submission, as incorporating a petition for extension of time for the appropriate length of time. An authorization to charge all required fees, fees under Section 1.17, or all required extension of time fees will be treated as a constructive petition for an extension of time in any concurrent or future reply requiring a petition for an extension of time under this paragraph for its timely submission. Submission of the fee set forth in Section 1.17(a) will also be treated as a constructive petition for an extension of time in any concurrent reply requiring a petition for an extension of time under this paragraph for its timely submission." 37 C.F.R. Section 1.136(a)(3).

NOTE: Section 1.311(b) provides that an authorization to charge the issue fee (§ 1.18) to a deposit account may be filed in an individual application **only after the mailing of the notice of allowance**. Accordingly, general authorizations to pay fees and specific authorizations to pay the issue fee that are filed prior to the mailing of a notice of allowance will generally not be treated as requesting payment of the issue fee and will not be given effect to act as a reply to the notice of allowance. Applicant, when paying the issue fee, should submit a new authorization to charge fees, such as by completing box 6b on the current PTOL-85B form. Where no reply to the notice of allowance is received, the application will stand abandoned notwithstanding the presence of general authorizations to pay fees or a specific authorization to pay the issue fee that were submitted prior to mailing of the notice of allowance. Where an attempt is made to pay the issue fee but an incorrect amount is submitted, § 1.311(b)(1), or where the Office's issue fee transmittal form (currently PTOL-85(B)) is completed by applicant and submitted, § 1.311(b)(2), in reply to a notice of allowance, an exception will be made. Such submissions will operate as a request to charge the issue fee to any deposit account identified in a previously filed (i.e., submitted prior to the mailing of the notice of allowance) authorization to charge fees, and will be allowed to act as payment of the correct issue fee, § 1.311(b). See also the change to § 1.26(b). Notice of September 8, 2000, Fed. Reg. 54603-54683, at 54646 and 54647.

15. Instructions as to Overpayment

NOTE: "... Amounts of twenty-five dollars or less will not be returned unless specifically requested within a reasonable time, nor will the payer be notified of such amounts; amounts over twenty-five dollars may be returned by check or, if requested, by credit to a deposit account." 37 C.F.R. Section 1.26(a).

- credit Account No. 12-0425
- refund



Signature of Practitioner - Customer No. 00140

Reg. No. 44063
Tel. No. (212) 708-1950

Raymond A. Diperna
Ladas & Parry LLP
1040 Avenue of the Americas
New York, NY 10018

Incorporation by reference of added pages

(Check the following item if the application in this transmittal claims the benefit of prior U.S. application(s) (including an international application entering the U.S. stage as a continuation, divisional or C-I-P application) and complete and attach the ADDED PAGES FOR NEW APPLICATION TRANSMITTAL WHERE BENEFIT OF PRIOR U.S. APPLICATION(S) CLAIMED)

Plus Added Pages for New Application Transmittal Where Benefit of Prior U.S. Application(s) Claimed

Number of pages added 0

Plus added pages deleting names of inventor(s) named on prior applications(s) who is/are no longer inventor(s) of the subject matter claimed in this application.

Number of pages added 0

Statement Where No Further Pages Added

(If no further pages form a part of this Transmittal, then end this Transmittal with this page and check the following item)

This transmittal ends with this page.

Under the Paperwork Reduction Act of 1995, no persons are required to respond to a collection of information unless it contains a valid OMB control number.

Application Data Sheet 37 CFR 1.76		Attorney Docket Number	U 020233-5
		Application Number	
Title of Invention	CRYPTOCURRENCY SYSTEM USING BODY ACTIVE DATA		
The application data sheet is part of the provisional or nonprovisional application for which it is being submitted. The following form contains the bibliographic data arranged in a format specified by the United States Patent and Trademark Office as outlined in 37 CFR 1.76. This document may be completed electronically and submitted to the Office in electronic format using the Electronic Filing System (EFS) or the document may be printed and included in a paper filed application.			

Secrecy Order 37 CFR 5.2:

<input type="checkbox"/>	Portions or all of the application associated with this Application Data Sheet may fall under a Secrecy Order pursuant to 37 CFR 5.2 (Paper filers only. Applications that fall under Secrecy Order may not be filed electronically.)
--------------------------	---

Inventor Information:

Inventor 1					Remove
Legal Name					
Prefix	Given Name	Middle Name	Family Name	Suffix	
	Dustin		ABRAMSON		
Residence Information (Select One) <input checked="" type="radio"/> US Residency <input type="radio"/> Non US Residency <input type="radio"/> Active US Military Service					
City	Renton	State/Province	WA	Country of Residence	US

Mailing Address of Inventor:

Address 1	One Microsoft Way				
Address 2					
City	Redmond	State/Province	WA		
Postal Code	98052	Country i	US		

Inventor 2					Remove
Legal Name					
Prefix	Given Name	Middle Name	Family Name	Suffix	
	Derrick		FU		
Residence Information (Select One) <input checked="" type="radio"/> US Residency <input type="radio"/> Non US Residency <input type="radio"/> Active US Military Service					
City	Seattle	State/Province	WA	Country of Residence	US

Mailing Address of Inventor:

Address 1	One Microsoft Way				
Address 2					
City	Redmond	State/Province	WA		
Postal Code	98052	Country i	US		

Inventor 3					Remove
Legal Name					
Prefix	Given Name	Middle Name	Family Name	Suffix	
	Joe		JOHNSON		
Residence Information (Select One) <input checked="" type="radio"/> US Residency <input type="radio"/> Non US Residency <input type="radio"/> Active US Military Service					

Under the Paperwork Reduction Act of 1995, no persons are required to respond to a collection of information unless it contains a valid OMB control number.

Application Data Sheet 37 CFR 1.76	Attorney Docket Number	U 020233-5
	Application Number	
Title of Invention	CRYPTOCURRENCY SYSTEM USING BODY ACTIVE DATA	

City	Seattle	State/Province	WA	Country of Residence ⁱ	US
------	---------	----------------	----	-----------------------------------	----

Mailing Address of Inventor:

Address 1	One Microsoft Way				
Address 2					
City	Redmond	State/Province	WA		
Postal Code	98052	Country ⁱ	US		

All Inventors Must Be Listed - Additional Inventor Information blocks may be generated within this form by selecting the **Add** button.

Correspondence Information:

Enter either Customer Number or complete the Correspondence Information section below. For further information see 37 CFR 1.33(a).

An Address is being provided for the correspondence information of this application.

Customer Number	156424		
Email Address	usdocket@microsoft.com	<input type="button" value="Add Email"/>	<input type="button" value="Remove Email"/>
Email Address	MicrosoftIP@ladas.com	<input type="button" value="Add Email"/>	<input type="button" value="Remove Email"/>

Application Information:

Title of the Invention	CRYPTOCURRENCY SYSTEM USING BODY ACTIVE DATA		
Attorney Docket Number	U 020233-5	Small Entity Status Claimed	<input type="checkbox"/>
Application Type	Nonprovisional		
Subject Matter	Utility		
Total Number of Drawing Sheets (if any)	8	Suggested Figure for Publication (if any)	

Filing By Reference:

Only complete this section when filing an application by reference under 35 U.S.C. 111(c) and 37 CFR 1.57(a). Do not complete this section if application papers including a specification and any drawings are being filed. Any domestic benefit or foreign priority information must be provided in the appropriate section(s) below (i.e., "Domestic Benefit/National Stage Information" and "Foreign Priority Information").

For the purposes of a filing date under 37 CFR 1.53(b), the description and any drawings of the present application are replaced by this reference to the previously filed application, subject to conditions and requirements of 37 CFR 1.57(a).

Application number of the previously filed application	Filing date (YYYY-MM-DD)	Intellectual Property Authority or Country ⁱ

Under the Paperwork Reduction Act of 1995, no persons are required to respond to a collection of information unless it contains a valid OMB control number.

Application Data Sheet 37 CFR 1.76	Attorney Docket Number	U 020233-5
	Application Number	
Title of Invention	CRYPTOCURRENCY SYSTEM USING BODY ACTIVE DATA	

Publication Information:

<input type="checkbox"/>	Request Early Publication (Fee required at time of Request 37 CFR 1.219)
<input type="checkbox"/>	Request Not to Publish. I hereby request that the attached application not be published under 35 U.S.C. 122(b) and certify that the invention disclosed in the attached application has not and will not be the subject of an application filed in another country, or under a multilateral international agreement, that requires publication at eighteen months after filing.

Representative Information:

Representative information should be provided for all practitioners having a power of attorney in the application. Providing this information in the Application Data Sheet does not constitute a power of attorney in the application (see 37 CFR 1.32). Either enter Customer Number or complete the Representative Name section below. If both sections are completed the customer Number will be used for the Representative Information during processing.

Please Select One:	<input checked="" type="radio"/> Customer Number	<input type="radio"/> US Patent Practitioner	<input type="radio"/> Limited Recognition (37 CFR 11.9)
Customer Number	156424		

Domestic Benefit/National Stage Information:

This section allows for the applicant to either claim benefit under 35 U.S.C. 119(e), 120, 121, 365(c), or 386(c) or indicate National Stage entry from a PCT application. Providing benefit claim information in the Application Data Sheet constitutes the specific reference required by 35 U.S.C. 119(e) or 120, and 37 CFR 1.78.

When referring to the current application, please leave the "Application Number" field blank.

Prior Application Status	<input type="text"/>	<input type="button" value="Remove"/>
Application Number	Continuity Type	Prior Application Number
<input type="text"/>	<input type="text"/>	Filing or 371(c) Date (YYYY-MM-DD)
<input type="text"/>	<input type="text"/>	<input type="text"/>
Additional Domestic Benefit/National Stage Data may be generated within this form by selecting the Add button.		<input type="button" value="Add"/>

Foreign Priority Information:

This section allows for the applicant to claim priority to a foreign application. Providing this information in the application data sheet constitutes the claim for priority as required by 35 U.S.C. 119(b) and 37 CFR 1.55. When priority is claimed to a foreign application that is eligible for retrieval under the priority document exchange program (PDX)¹ the information will be used by the Office to automatically attempt retrieval pursuant to 37 CFR 1.55(i)(1) and (2). Under the PDX program, applicant bears the ultimate responsibility for ensuring that a copy of the foreign application is received by the Office from the participating foreign intellectual property office, or a certified copy of the foreign priority application is filed, within the time period specified in 37 CFR 1.55(g)(1).

Under the Paperwork Reduction Act of 1995, no persons are required to respond to a collection of information unless it contains a valid OMB control number.

Application Data Sheet 37 CFR 1.76	Attorney Docket Number	U 020233-5
	Application Number	
Title of Invention	CRYPTOCURRENCY SYSTEM USING BODY ACTIVE DATA	

Application Number	Country ⁱ	Filing Date (YYYY-MM-DD)	Access Code ^j (if applicable)

Additional Foreign Priority Data may be generated within this form by selecting the **Add** button.

Statement under 37 CFR 1.55 or 1.78 for AIA (First Inventor to File) Transition Applications

This application (1) claims priority to or the benefit of an application filed before March 16, 2013 and (2) also contains, or contained at any time, a claim to a claimed invention that has an effective filing date on or after March 16, 2013.

NOTE: By providing this statement under 37 CFR 1.55 or 1.78, this application, with a filing date on or after March 16, 2013, will be examined under the first inventor to file provisions of the AIA.

Under the Paperwork Reduction Act of 1995, no persons are required to respond to a collection of information unless it contains a valid OMB control number.

Application Data Sheet 37 CFR 1.76	Attorney Docket Number	U 020233-5
	Application Number	
Title of Invention	CRYPTOCURRENCY SYSTEM USING BODY ACTIVE DATA	

Authorization or Opt-Out of Authorization to Permit Access:

When this Application Data Sheet is properly signed and filed with the application, applicant has provided written authority to permit a participating foreign intellectual property (IP) office access to the instant application-as-filed (see paragraph A in subsection 1 below) and the European Patent Office (EPO) access to any search results from the instant application (see paragraph B in subsection 1 below).

Should applicant choose not to provide an authorization identified in subsection 1 below, applicant **must opt-out** of the authorization by checking the corresponding box A or B or both in subsection 2 below.

NOTE: This section of the Application Data Sheet is **ONLY** reviewed and processed with the **INITIAL** filing of an application. After the initial filing of an application, an Application Data Sheet cannot be used to provide or rescind authorization for access by a foreign IP office(s). Instead, Form PTO/SB/39 or PTO/SB/69 must be used as appropriate.

1. Authorization to Permit Access by a Foreign Intellectual Property Office(s)

A. Priority Document Exchange (PDX) - Unless box A in subsection 2 (opt-out of authorization) is checked, the undersigned hereby **grants the USPTO authority** to provide the European Patent Office (EPO), the Japan Patent Office (JPO), the Korean Intellectual Property Office (KIPO), the State Intellectual Property Office of the People's Republic of China (SIPO), the World Intellectual Property Organization (WIPO), and any other foreign intellectual property office participating with the USPTO in a bilateral or multilateral priority document exchange agreement in which a foreign application claiming priority to the instant patent application is filed, access to: (1) the instant patent application-as-filed and its related bibliographic data, (2) any foreign or domestic application to which priority or benefit is claimed by the instant application and its related bibliographic data, and (3) the date of filing of this Authorization. See 37 CFR 1.14(h) (1).

B. Search Results from U.S. Application to EPO - Unless box B in subsection 2 (opt-out of authorization) is checked, the undersigned hereby **grants the USPTO authority** to provide the EPO access to the bibliographic data and search results from the instant patent application when a European patent application claiming priority to the instant patent application is filed. See 37 CFR 1.14(h)(2).

The applicant is reminded that the EPO's Rule 141(1) EPC (European Patent Convention) requires applicants to submit a copy of search results from the instant application without delay in a European patent application that claims priority to the instant application.

2. Opt-Out of Authorizations to Permit Access by a Foreign Intellectual Property Office(s)

A. Applicant **DOES NOT** authorize the USPTO to permit a participating foreign IP office access to the instant application-as-filed. If this box is checked, the USPTO will not be providing a participating foreign IP office with any documents and information identified in subsection 1A above.

B. Applicant **DOES NOT** authorize the USPTO to transmit to the EPO any search results from the instant patent application. If this box is checked, the USPTO will not be providing the EPO with search results from the instant application.

NOTE: Once the application has published or is otherwise publicly available, the USPTO may provide access to the application in accordance with 37 CFR 1.14.

Under the Paperwork Reduction Act of 1995, no persons are required to respond to a collection of information unless it contains a valid OMB control number.

Application Data Sheet 37 CFR 1.76	Attorney Docket Number	U 020233-5
	Application Number	
Title of Invention	CRYPTOCURRENCY SYSTEM USING BODY ACTIVE DATA	

Applicant Information:

Providing assignment information in this section does not substitute for compliance with any requirement of part 3 of Title 37 of CFR to have an assignment recorded by the Office.

Applicant	1	<input type="button" value="Remove"/>
<p>If the applicant is the inventor (or the remaining joint inventor or inventors under 37 CFR 1.45), this section should not be completed. The information to be provided in this section is the name and address of the legal representative who is the applicant under 37 CFR 1.43; or the name and address of the assignee, person to whom the inventor is under an obligation to assign the invention, or person who otherwise shows sufficient proprietary interest in the matter who is the applicant under 37 CFR 1.46. If the applicant is an applicant under 37 CFR 1.46 (assignee, person to whom the inventor is obligated to assign, or person who otherwise shows sufficient proprietary interest) together with one or more joint inventors, then the joint inventor or inventors who are also the applicant should be identified in this section.</p>		
<input type="button" value="Clear"/>		
Assignee	Legal Representative under 35 U.S.C. 117	Joint Inventor
<input type="checkbox"/> Person to whom the inventor is obligated to assign.	<input type="checkbox"/> Person who shows sufficient proprietary interest	
If applicant is the legal representative, indicate the authority to file the patent application, the inventor is:		
<div style="border: 1px solid black; height: 20px; width: 100%;"></div>		
Name of the Deceased or Legally Incapacitated Inventor: <input style="width: 90%;" type="text"/>		
If the Applicant is an Organization check here. <input checked="" type="checkbox"/>		
Organization Name	Microsoft Technology Licensing, LLC	
Mailing Address Information For Applicant:		
Address 1	One Microsoft Way	
Address 2		
City	Redmond	State/Province
Country	US	Postal Code
Phone Number		Fax Number
Email Address	usdocket@microsoft.com	
Additional Applicant Data may be generated within this form by selecting the Add button. <input type="button" value="Add"/>		

Assignee Information including Non-Applicant Assignee Information:

Providing assignment information in this section does not substitute for compliance with any requirement of part 3 of Title 37 of CFR to have an assignment recorded by the Office.

Under the Paperwork Reduction Act of 1995, no persons are required to respond to a collection of information unless it contains a valid OMB control number.

Application Data Sheet 37 CFR 1.76	Attorney Docket Number	U 020233-5
	Application Number	
Title of Invention	CRYPTOCURRENCY SYSTEM USING BODY ACTIVE DATA	

Assignee	1		
Complete this section if assignee information, including non-applicant assignee information, is desired to be included on the patent application publication. An assignee-applicant identified in the "Applicant Information" section will appear on the patent application publication as an applicant. For an assignee-applicant, complete this section only if identification as an assignee is also desired on the patent application publication.			
			<input type="button" value="Remove"/>
If the Assignee or Non-Applicant Assignee is an Organization check here.			<input checked="" type="checkbox"/>
Organization Name	Microsoft Technology Licensing, LLC		
Mailing Address Information For Assignee including Non-Applicant Assignee:			
Address 1	One Microsoft Way		
Address 2			
City	Redmond	State/Province	WA
Country ⁱ	US	Postal Code	98052
Phone Number		Fax Number	
Email Address	usdocket@microsoft.com		
Additional Assignee or Non-Applicant Assignee Data may be generated within this form by selecting the Add button.			<input type="button" value="Add"/>

Signature:

NOTE: This Application Data Sheet must be signed in accordance with 37 CFR 1.33(b). However, if this Application Data Sheet is submitted with the **INITIAL** filing of the application and either box A or B is not checked in subsection 2 of the "Authorization or Opt-Out of Authorization to Permit Access" section, then this form must also be signed in accordance with 37 CFR 1.14(c).

This Application Data Sheet **must** be signed by a patent practitioner if one or more of the applicants is a **juristic entity** (e.g., corporation or association). If the applicant is two or more joint inventors, this form must be signed by a patent practitioner, **all** joint inventors who are the applicant, or one or more joint inventor-applicants who have been given power of attorney (e.g., see USPTO Form PTO/AIA/81) on behalf of **all** joint inventor-applicants.

See 37 CFR 1.4(d) for the manner of making signatures and certifications.

Signature	/Raymond A. DiPerna/		Date (YYYY-MM-DD)	2018-09-21	
First Name	Raymond	Last Name	DiPerna	Registration Number	44,063
Additional Signature may be generated within this form by selecting the Add button.				<input type="button" value="Add"/>	

Under the Paperwork Reduction Act of 1995, no persons are required to respond to a collection of information unless it contains a valid OMB control number.

Application Data Sheet 37 CFR 1.76	Attorney Docket Number	U 020233-5
	Application Number	
Title of Invention	CRYPTOCURRENCY SYSTEM USING BODY ACTIVE DATA	

This collection of information is required by 37 CFR 1.76. The information is required to obtain or retain a benefit by the public which is to file (and by the USPTO to process) an application. Confidentiality is governed by 35 U.S.C. 122 and 37 CFR 1.14. This collection is estimated to take 23 minutes to complete, including gathering, preparing, and submitting the completed application data sheet form to the USPTO. Time will vary depending upon the individual case. Any comments on the amount of time you require to complete this form and/or suggestions for reducing this burden, should be sent to the Chief Information Officer, U.S. Patent and Trademark Office, U.S. Department of Commerce, P.O. Box 1450, Alexandria, VA 22313-1450. DO NOT SEND FEES OR COMPLETED FORMS TO THIS ADDRESS. **SEND TO: Commissioner for Patents, P.O. Box 1450, Alexandria, VA 22313-1450.**

Privacy Act Statement

The Privacy Act of 1974 (P.L. 93-579) requires that you be given certain information in connection with your submission of the attached form related to a patent application or patent. Accordingly, pursuant to the requirements of the Act, please be advised that: (1) the general authority for the collection of this information is 35 U.S.C. 2(b)(2); (2) furnishing of the information solicited is voluntary; and (3) the principal purpose for which the information is used by the U.S. Patent and Trademark Office is to process and/or examine your submission related to a patent application or patent. If you do not furnish the requested information, the U.S. Patent and Trademark Office may not be able to process and/or examine your submission, which may result in termination of proceedings or abandonment of the application or expiration of the patent.

The information provided by you in this form will be subject to the following routine uses:

1. The information on this form will be treated confidentially to the extent allowed under the Freedom of Information Act (5 U.S.C. 552) and the Privacy Act (5 U.S.C. 552a). Records from this system of records may be disclosed to the Department of Justice to determine whether the Freedom of Information Act requires disclosure of these records.
2. A record from this system of records may be disclosed, as a routine use, in the course of presenting evidence to a court, magistrate, or administrative tribunal, including disclosures to opposing counsel in the course of settlement negotiations.
3. A record in this system of records may be disclosed, as a routine use, to a Member of Congress submitting a request involving an individual, to whom the record pertains, when the individual has requested assistance from the Member with respect to the subject matter of the record.
4. A record in this system of records may be disclosed, as a routine use, to a contractor of the Agency having need for the information in order to perform a contract. Recipients of information shall be required to comply with the requirements of the Privacy Act of 1974, as amended, pursuant to 5 U.S.C. 552a(m).
5. A record related to an International Application filed under the Patent Cooperation Treaty in this system of records may be disclosed, as a routine use, to the International Bureau of the World Intellectual Property Organization, pursuant to the Patent Cooperation Treaty.
6. A record in this system of records may be disclosed, as a routine use, to another federal agency for purposes of National Security review (35 U.S.C. 181) and for review pursuant to the Atomic Energy Act (42 U.S.C. 218(c)).
7. A record from this system of records may be disclosed, as a routine use, to the Administrator, General Services, or his/her designee, during an inspection of records conducted by GSA as part of that agency's responsibility to recommend improvements in records management practices and programs, under authority of 44 U.S.C. 2904 and 2906. Such disclosure shall be made in accordance with the GSA regulations governing inspection of records for this purpose, and any other relevant (i.e., GSA or Commerce) directive. Such disclosure shall not be used to make determinations about individuals.
8. A record from this system of records may be disclosed, as a routine use, to the public after either publication of the application pursuant to 35 U.S.C. 122(b) or issuance of a patent pursuant to 35 U.S.C. 151. Further, a record may be disclosed, subject to the limitations of 37 CFR 1.14, as a routine use, to the public if the record was filed in an application which became abandoned or in which the proceedings were terminated and which application is referenced by either a published application, an application open to public inspections or an issued patent.
9. A record from this system of records may be disclosed, as a routine use, to a Federal, State, or local law enforcement agency, if the USPTO becomes aware of a violation or potential violation of law or regulation.

CRYPTOCURRENCY SYSTEM USING BODY ACTIVITY DATA

BACKGROUND

[0001] A virtual currency (also known as a digital currency) is a medium of exchange implemented through the Internet generally, not tied to a specific government-backed “flat” (printed) currency such as the U.S. dollar or the Euro, and typically designed to allow instantaneous transactions and borderless transfer of ownership. One example of virtual currency is cryptocurrency, wherein cryptography is used to secure transactions and to control the creation of new units.

[0002] Several cryptocurrencies exist. Among these, the most well known is a blockchain-based cryptocurrency. Most blockchain-based cryptocurrency is decentralized in the sense that it has no central point of control. However, blockchain-based cryptocurrency can also be implemented in a centralized system having a central point of control over the cryptocurrency. Bitcoin is one of the examples of blockchain-based cryptocurrency. It is described in a 2008 article by Satoshi Nakamoto, named “Bitcoin: A peer-to-Peer Electronic Cash System,” the entire content of which is incorporated herein by reference.

[0003] A blockchain is a data structure that stores a list of transactions and can be thought of as a distributed electronic ledger that records transactions between source identifier(s) and destination identifier(s). The transactions are bundled into blocks and every block (except for the first block) refers back to or is linked to a prior block in the blockchain. Computer resources (or nodes, etc.) maintain the blockchain and cryptographically validate each new block and the transactions contained in the corresponding block. This validation process includes computationally solving a difficult problem that is also easy to verify and is sometimes called a “proof-of-work”. This process is referred to as “mining”. The mining may be a random process with low probability so that a lot of trial and error is required to solve a computationally difficult problem. Accordingly, the mining may require enormous amounts of computational energy.

[0004] It is with respect to these and other general considerations that the following embodiments have been described. Also, although relatively specific problems have been discussed, it should be understood that the embodiments should not be limited to solving the specific problems identified in the background.

SUMMARY

[0005] Some exemplary embodiments of the present disclosure may use human body activity associated with a task provided to a user as a solution to “mining” challenges in cryptocurrency systems. For example, a brain wave or body heat emitted from the user when the user performs the task provided by an information or service provider, such as viewing advertisement or using certain internet services, can be used in the mining process. Instead of massive computation work required by some conventional cryptocurrency systems, data generated based on the body activity of the user can be a proof-of-work, and therefore, a user can solve the computationally difficult problem unconsciously. Accordingly, certain exemplary embodiments of the present disclosure may reduce computational energy for the mining process as well as make the mining process faster.

[0006] Systems, methods, and hardware aspects of computer readable storage media are provided herein for a cryptocurrency system using human body activity data. According to various embodiments of the present disclosure, a server may provide a task to a device of a user which is communicatively coupled to the server. A sensor communicatively coupled to or comprised in the device of the user may sense body activity of the user. Body activity data may be generated based on the sensed body activity of the user. A cryptocurrency system communicatively coupled to the device of the user may verify whether or not the body activity data satisfies one or more conditions set by the cryptocurrency system, and award cryptocurrency to the user whose body activity data is verified.

[0007] Examples are implemented as a computer process, a computing system, or as an article of manufacture such as a device, computer program product, or computer readable medium. According to one aspect, the computer program product is a computer storage medium readable by a computer system and encoding a computer program comprising instructions for executing a computer process.

[0008] This summary is provided to introduce a selection of concepts in a simplified form that are further described below in the Detailed Description. This summary is not intended to identify key features or essential features of the claimed subject matter, nor is it intended to be used to limit the scope of the claimed subject matter.

BRIEF DESCRIPTION OF THE DRAWINGS

[0009] Various embodiments in accordance with the present disclosure will be described with reference to the drawings, in which:

[0010] FIG. 1 illustrates an example environment in which some exemplary embodiments of the present disclosure may be practiced;

[0011] FIG. 2 shows a system diagram of a decentralized cryptocurrency system according to an exemplary embodiment of the present disclosure;

[0012] FIG. 3 shows a flow diagram of a computer-implemented method according to an exemplary embodiment of the present disclosure;

[0013] FIG. 4 shows a flow diagram of an operation for generating body activity data according to an exemplary embodiment of the present disclosure;

[0014] FIG. 5 shows a flow diagram of an operation for verifying body activity data according to an exemplary embodiment of the present disclosure;

[0015] FIG. 6 illustrates a blockchain and two exemplary blocks of the blockchain according to an exemplary embodiment of the present disclosure;

[0016] FIG. 7 shows a flow diagram of a computer-implemented method using a vector or embedding according to another exemplary embodiment of the present disclosure; and

[0017] FIG. 8 illustrates an exemplary block diagram of a computer or processing system in which processes involved in the system, method, and computer program product described herein may be implemented.

[0018] Corresponding numerals and symbols in the different figures generally refer to corresponding parts unless otherwise indicated. The figures are drawn to clearly illustrate the relevant aspects of the embodiments and are not necessarily drawn to scale.

DETAILED DESCRIPTION OF EMBODIMENTS

[0019] In the following detailed description, reference is made to the accompanying drawings which form a part hereof, and in which are shown by way of illustration specific embodiments in which the invention may be practiced. These embodiments are described in sufficient detail

to enable those skilled in the art to practice the invention, and it is to be understood that other embodiments may be utilized and that structural, logical and electrical changes may be made without departing from the spirit and scope of the invention. The following detailed description is therefore not to be taken in a limiting sense, and the scope of the invention is defined only by the appended claims and equivalents thereof. Like numbers in the figures refer to like components, which should be apparent from the context of use.

[0020] The term “cryptocurrency” may mean a digital currency in which encryption techniques are used to regulate the generation of units of currency and verify the transfer of funds. Many cryptocurrencies include the use of a blockchain to provide security and prevent fraud as double spending. Some embodiments of the present disclosure may be used in alternate cryptocurrency mechanisms other than a blockchain. The system, method, and computer program products described herein may be applied to both centralized and decentralized cryptocurrency networks or databases.

[0021] FIG. 1 illustrates an example environment 100 in which some exemplary embodiments of the present disclosure may be practiced. The example environment 100 includes, but is not limited to, at least one of task server 110, communication network 120, user device 130, sensor 140, and cryptocurrency system 150.

[0022] Task server 110 may provide one or more tasks to user device 130 over communication network 120. For example, task server 110 may be at least one of a web server delivering or serving up web pages, an application server handling application operations between users and applications or databases, a cloud server, a database server, a file server, a service server, a game server implementing games or services for a game, and a media server delivering media such as streaming video or audio. The tasks provided by task server 110 will be discussed in more detail below.

[0023] Alternatively, cryptocurrency system 150 may provide one or more tasks to user device 130. For example, in a decentralized cryptocurrency network, the tasks may be proposed to user device 130 by miners (e.g. compute resources or nodes 210 of FIG. 2). In another example, in a centralized cryptocurrency system, a cryptocurrency server may send the tasks to user device 130.

[0024] Communication network 120 may include any wired or wireless connection, the internet, or any other form of communication. Although one network 120 is identified in FIG.

1, communication network 120 may include any number of different communication networks between any of the server, devices, resource and system shown in FIGS. 1 and 2 and/or other servers, devices, resources and systems described herein. Communication network 120 may enable communication between various computing resources or devices, servers, and systems. Various implementations of communication network 120 may employ different types of networks, for example, but not limited to, computer networks, telecommunications networks (e.g., cellular), mobile wireless data networks, and any combination of these and/or other networks.

[0025] User device 130 may include any device capable of processing and storing data/information and communicating over communication network 120. For example, user device 130 may include personal computers, servers, cell phones, tablets, laptops, smart devices (e.g. smart watches or smart televisions). An exemplary embodiment of user device 130 is illustrated in FIG. 6.

[0026] Sensor 140 may be configured to sense the body activity of user 145. As illustrated in FIG. 1, sensor 140 may be a separate component from user device 130 and be operably and/or communicatively connected to user device 130. Alternatively, sensor 140 may be included and integrated in user device 130. For example, user device 130 may be a wearable device having sensor 140 therein. The sensor 140 may transmit information/data to user device 130. Sensor 140 may include, for example, but not limited to, functional magnetic resonance imaging (fMRI) scanners or sensors, electroencephalography (EEG) sensors, near infrared spectroscopy (NIRS) sensors, heart rate monitors, thermal sensors, optical sensors, radio frequency (RF) sensors, ultrasonic sensors, cameras, or any other sensor or scanner that can measure or sense body activity or scan human body. For instance, the fMRI may measure body activity by detecting changes associated with blood flow. The fMRI may use a magnetic field and radio waves to create detailed images of the body (e.g. blood flow in the brain to detect areas of activity). The material (<http://news.berkeley.edu/2011/09/22/brain-movies/>), the entire content of which is incorporated herein by reference, shows one example of how the fMRI can measure brain activity associated with visual information and generate image data.

[0027] Cryptocurrency system 150 may include one or more processors for processing commands and one or more memories storing information in one or more cryptocurrency data structures. In some embodiments, cryptocurrency system 150 may be a centralized cryptocurrency system or network, for example, but not limited to, a server which may be

privately run by a third party entity or the same entity that is running the task server 110. In other embodiments, cryptocurrency system 150 may be a publically accessible network system (e.g., a distributed decentralized computing system).

[0028] For example, cryptocurrency system 150 may be a decentralized network 200, such as a decentralized blockchain network, including one or more compute resources 210, as shown, for example, in FIG. 2. In the embodiment of FIG. 2, there may be no central authority controlling cryptocurrency network 200. The data stored on blockchain network 200, i.e., the public ledger, may not be stored at a central location in its entirety. Blockchain network 200 may include a plurality of processors for processing commands and a plurality of memories storing information in one or more blockchain data structures. Blockchain network 200 may maintain one or more blockchains of continuously growing lists of data blocks, where each data block refers to previous blocks on its list. The requirement for each block to refer to all previous blocks in the blockchain, yields a chain of blocks that is hardened against tampering and revision, such that the information stored in the blockchain is immutable.

[0029] Compute resources 210 may include any device, computer, system or otherwise that has joined blockchain network 200 and forms a node in blockchain network 200. Compute resources 210 may include, for example, but not limited to, personal computers, servers, cell phones, tablets, laptops, smart devices (e.g. smart watches or smart televisions), or any other device capable of storing information and communicating over communication network 120. In some embodiments, compute resources 210 may be unaffiliated with or unknown to each other where, for example, compute resources 210 remain anonymous. Each compute resource 210 may include memory 220 that stores a copy of at least a portion of public ledger 230 of blockchain network 200. Compute resources 210 may also execute one or more programs to perform various functions associated with maintaining blockchain network 200 including, for example, updating public ledger 230, generating new blocks, or any other similar function.

[0030] For illustration purposes, FIG. 1 illustrates user device 130 as not included in blockchain network 200. However, user device 130 may be part of blockchain network 200 and be implemented as one of the compute resources 210 in FIG. 2.

[0031] Public ledger 230 may store any transactions performed over blockchain network 200 including but not limited to, for example, any transaction related to and occurring on blockchain network 200. Because each compute resource 210 stores a copy of at least a portion of the public ledger 230 of blockchain network 200, public ledger 230 may be independently verified for accuracy at any time by comparing the stored copies of multiple compute resources

210.

[0032] Communication between compute resources 210 may occur via communication network 120. Communication network 120 of FIG. 2 may be the same network as, or be a different network from, communication 120 of FIG. 1. In some embodiments, each compute resource 210 may communicate directly with each other compute resource 210. In some embodiments, some compute resources 210 may not be able to communicate directly with each other. For example, they are not connected to the same communications network 120. In this case, communications related to blockchain network 200 between the compute resources 210 may occur by using one or more of the remaining compute resources 210 as an intermediary. In some embodiments, one or more of compute resources 210 may not maintain a continuous connection to blockchain network 200 at all times. For example, a compute resource 210 may only be connected to blockchain network 200 during a certain period of time each day or may only be connected to blockchain network 200 intermittently throughout the day. Due to the decentralized nature of blockchain network 200, such an intermittent connection by one or more compute resources 210 does not affect the overall operation of blockchain network 200 since copies of public ledger 230 are stored on multiple compute resources 210. Once the disconnected compute resource 210 reconnects to blockchain network 200, the disconnected compute resource 210 may receive updated copies of the public ledger 230 from one or more of the compute resources 210 that have been connected to blockchain network 200.

[0033] FIG. 3 shows a flow diagram of a computer-implemented method according to an exemplary embodiment of the present disclosure.

[0034] Method 300 begins at operation 310 illustrated in FIG. 3, where task server 110 provides one or more tasks to device 130 of user 145 over communication network 120. The tasks include, for example, but not limited to, watching or listening information (e.g. advertisement) for a certain time, using services (e.g. search engine, chat bot, e-mail, social media/networking service and any internet or web service), uploading or sending information/data to a website, a server or a network (e.g. content sharing website, and cloud network or server), or any other information or service which may produce effects on users. In the blockchain, the task(s) may be included as a transaction in the public ledger 230.

[0035] Furthermore, the task(s) provided by task server 110 can include solving a test for distinguishing human from machine input so that humans but not computers are able to pass it, such as, Computer Automated Program to Tell Computers and Humans Apart (CAPTCHA) and reCAPTCHA which is a CAPTCHA-like system designed to establish that a computer user

is human. The task may require user 145 to solve a verification challenge, for example, but not limited to, an image based challenge including instructions prompting user 145 to solve the challenge through interaction with one or more images.

[0036] At operation 320, when or after user 145 performs the task(s) provided by task server 110, sensor 140 may sense the body activity of user 145 that is a body response related to the task provided by task server 110, and then transmit the sensed body activity of user 145 to user device 130. The body activity may include, for example, but not limited to, radiation emitted from human body, brain activities, body fluid flow (e.g. blood flow), organ activity or movement, body movement, and any other activities that can be sensed and represented by images, waves, signals, texts, numbers, degrees, or any other form of information or data. Examples of body radiation emitted from human body may include radiant heat of the body, pulse rate, or brain wave. Brain waves may comprise, for example, but not limited to, (i) gamma waves, involved in learning or memory tasks, (ii) beta waves, involved in logical thinking and/or conscious thought, (iii) alpha waves, which may be related to subconscious thoughts, (iv) theta waves, which may be related to thoughts involving deep and raw emotions, (v) delta waves, which may be involved in sleep or deep relaxation, or (vi) electroencephalogram (EEG), which may be measurement used to evaluate the electrical activity in the brain, such as deep concentration. Examples of the body movement may include eye movement, facial movement or any other muscular movements. Furthermore, brain activity can be sensed using the fMRI. The fMRI measures brain activity by detecting changes associated with blood flow. This technique relies on the fact that cerebral blood flow and neuronal activation are coupled. When an area of the brain is in use, blood flow to that region also increases.

[0037] At operation 330, user device 130 generates body activity data based on the body activity sensed by sensor 140. Operation 330 may be part of a mining process which is a process for solving a computationally difficult problem. One exemplary embodiment of operation 330 is shown in FIG. 4. As shown in FIG. 4, operation 330 may comprise operations 410 and 420.

[0038] At operation 410, the body activity sensed by sensor 140 may be codified in symbolic forms, such as letter(s), numeral(s), symbol(s), and a string comprising sequence of characters. In one example, the body activity can be codified by extracting one or more values from the sensed body activity, such as minimum and/or maximum amplitude(s) or frequency(ies) of a body activity signal (e.g. brain waves). In another example, user device 130 may window and

sample the sensed body activity over time and calculate the average of the sampled values. In still another example, user device 130 may generate raw data of the body activity. In still another example, user device 130 may filter a raw signal of the body activity using one or more filters to apply the filtered body activity signal to an audio hash function or algorithm at operation 420. Alternatively, any statistic value(s) associated with human body activity can be codified from the body activity sensed by sensor 140.

[0039] At operation 420, the codified body activity may be converted into an encrypted output by using an encryption algorithm, such as a hash algorithm or function. For example, hash functions include functions that map an initial input data set of an output data set. Generally, the hash function may be any function that can be used to map data of arbitrary size to data of fixed size. The hash function allows one to easily verify that some input data maps to a given hash value, but if the input data is unknown, it is deliberately difficult to reconstruct it (or any equivalent alternatives) by knowing the stored hash value. The hash algorithm or function may be included in the mining software or program of the cryptocurrency system or database.

[0040] For example, operation 420 may use audio hash function, where the histogram of frequencies of the codified body activity are summed up, or bit manipulation, such as XOR function of each histogram bucket with the next or a modulus of a prime number, is performed on the codified body activity.

[0041] In some embodiments, an analog hash function where the body activities themselves are hashes can be used. For example, waves or signals sensed by sensor 140, for example, but not limited to, alpha, beta, delta or gamma waves from the EEG sensor, may be transformed to a histogram using a transforming algorithm or formula, such as Fast Fourier Transform (FFT) or any other algorithm or formula that can convolve, add or multiply waves or signals to produce a histogram. The hash may be the histogram itself. For example, the hash may be the output of the FFT where each component is a frequency band and the value is counts corresponding to each frequency band. In another example, the desired properties may be that the first two frequency histograms are as close to zero as possible, for instance, provided some statistical guarantee exists that this cannot happen easily.

[0042] However, operation 420 is optional. In certain embodiments, user device 130, without encrypting or hashing the codified body activity, may transmit the codified body activity generated at operation 410 to cryptocurrency system 150.

[0043] Although FIG. 3 illustrates that operation 330, including operation 410 and 420, is processed by user device 130, at least one of operations 410 and 420 can be processed by

another device(s), server, resource or system, such as task server 110, cryptocurrency system 150 or any other server. For example, the user device 130 may generate raw data of the sensed body activity, transmit it to cryptocurrency system 150, task server 110 or any other server, and then cryptocurrency system 150, task server 110 or any other server may codify or hash the raw data of the sensed body activity.

[0044] Referring back to FIG. 3, at operation 340, cryptocurrency system 150 verifies if the body activity data of user 145 generated by user device 130 satisfies one or more conditions set by an algorithm of cryptocurrency system 150. The conditions may be set by simulating human body activity across all of body activities that can constitute hashes. Machine learning algorithms may be used to simulate body activities and set the conditions for valid body activities, for example, but not limited to, using generative adversarial networks.

[0045] In some embodiments, cryptocurrency system 150 verifies whether the body activity data of user 145 (e.g. the code of the body activity generated at operation 410 or the hash of the body activity generated at operation 420) may represent that the body activity of user 145 is within a target range. The target range may be determined using the amount of cognitive effort that user 145 requires to perform the task provided by task server 110. For example, to verify if the hash of the body activity of user 145, cryptocurrency system 150 may determine, for example, but not limited to, (i) whether the hash of the body activity of user 145 has a specific certain pattern, repeated patterns, a mathematical properties or the number of leading numbers, characters or strings (e.g. leading zeroes) set by cryptocurrency system 150, or (ii) whether the hash of the body activity of user 145 is less than a current target value. Examples of the numerical patterns set by cryptocurrency system 150 may be a pattern that first certain digits of the hash form a prime number, or a pattern that a number that is calculated by applying first certain digits of the hash to a preset formula forms a prime number (For example, a number calculated by adding or subtracting a predetermined number or a number set by cryptocurrency system 150 to the first four digits of the hashing forms a prime number). The repeating number patterns may include a repeating number (e.g. leading zeros, ones in the middle of the hash, twos in the last four digits of the hash, and any repeating numbers included in the hash) and a repeating number sequence (e.g. leading repeating digit pairs, such as "121212", or triplets "123123"). If the hash of the body activity of user 145 has the desirable pattern(s) or is within the target range, then the proof of work or proof of stake is considered solved, and that hash can be a new block. The target range or value may be changed periodically to maintain a preselected level of difficulty, although it is not required. For example, the target value may

be inversely proportional to the difficulty. By varying the difficulty, a roughly constant rate of block generation may be kept.

[0046] The target range of valid body activity may be set using statistical data so that normal body activity, activity that can easily happen, or faking body activity cannot be validated. For example, the target range of valid body activity may be selected from a range that human miners cannot fake their own body activity to satisfy the target range to prove and validate the proof-of-work.

[0047] Additionally, the verification at operation 340 may include filtering out invalid tasks, malformed data (syntax errors) or data sent from an unauthorized user or generated by a machine learning system. For example, cryptocurrency system 150 may receive, from user device 130, data of the body activity generated before the hash algorithm is applied, rehash that data, and then compare the rehashed data with the hash received from user device 130 to check whether the body activity data is generated based on human, not random computer generated data. Voxel(s) of the image of the fMRI may be an example of the data of the body activity generated before the hash algorithm is applied.

[0048] One exemplary embodiment of operation 340 is shown in FIG. 5. At operation 510, cryptocurrency system 150 may check whether the hash of the body activity, received from user device 130, is within the target range set by cryptocurrency system 150, or comprises a desirable pattern set by cryptocurrency system 150. If the hash of the body activity is within the target range or has a desirable pattern set by cryptocurrency system 150, cryptocurrency system 150 rehashes data of the body activity, generated before the hash algorithm is applied and transmitted with the hash of the body activity from user device 130 (Operation 520), and then compare the rehashed data with the hash of the body activity, received from user device 130 (Operation 530). If the rehashed data is identical to the hash of the body activity, received from user device 130, cryptocurrency system 150 proceeds to operation 350. However, if determining in operation 510 that the hash of the body activity data is out of the target range or does not include the desirable pattern set by cryptocurrency system 150 or if determining in operation 530 that the rehashed data does not match the hash of the body activity, operation 310 or 320 may be proceeded.

[0049] At operation 350, when the body activity data transmitted from user device 130 satisfies one or more conditions set by cryptocurrency system 150, cryptocurrency system 150 awards cryptocurrency to user 145. For example, cryptocurrency system 150 awards to user 145 an amount of cryptocurrency corresponding to the task accomplished by user 145. Additionally,

cryptocurrency system 150 may award cryptocurrency to an owner or operator of task server 110 as a reward for providing services, such as, search engines, chatbots, applications or websites, offering users access for free to paid contents (e.g. video and audio streaming or electric books), or sharing information or data with users.

[0050] For example, in the blockchain cryptocurrency system, at operation 340, at least one of compute resources 210 of FIG. 2 verifies if the hash of the body activity data of user 145 is valid. At operation 350, when the hash of the body activity data of user 145 is validated at operation 340, the compute resource 210 of FIG. 2 can add a new block to the blockchain. The new block may contain the number of cryptocurrency units assigned to the user's address. The new blockchain with the additional added block is broadcasted around the cryptocurrency network 150. The compute resource 210, which performed operations 340 and 350, may be also rewarded with transaction fees and/or cryptocurrency.

[0051] FIG. 5 depicts a blockchain 500 and two exemplary blocks 510, 520 of blockchain 500 according to exemplary embodiments of the present disclosure. Typically a "blockchain" is understood as being a data structure comprising a series of blocks, where each block includes data corresponding to one or more transactions, hashed together with linking data, such as the hash of an immediately preceding block. In the embodiment of the present disclosure, the transaction may be the task performed by user 145. The chain can then be used to create a ledger, which is typically an append-only database. Once data is entered into a block of the chain, the entry is essentially irrefutable, since any tampering with the data would be reflected in the chained hash calculations and is thus easily detected.

[0052] The blockchain 500 may represent the publicly distributable transactions ledger, such as ledger 230 of FIG. 2, and may include a plurality of blocks. Each block, such as block 510 and block 520 may include data regarding recent transactions. For example, the task performed by user 145 and the number of cryptocurrency units awarded to user 145, and/or contents linking data that links one block 520 to a previous block 510, and proof-of-work data, for example, the validated hash of the body activity, that ensures that the state of the blockchain 500 is valid and is endorsed/verified by a majority of the record keeping system. Exemplary embodiments of block 520 of blockchain 500 may include a current hash, a previous hash of previous block 510, transaction. The previous hash is a hash from the immediately preceding block, which ensures that each block is immutably tied to previous block. The hash of previous block 510 may be included in block 520, thereby linking block 520 to previous block 510.

[0053] Transaction information cannot be modified without at least one of compute resources

210 noticing, thus, the blockchain 500 can be trusted to verify transactions occurring on blockchain 500.

[0054] In some embodiments, vectors or embeddings may be used for body activity data. FIG. 7 shows a flow diagram of an exemplary embodiment of a computer-implemented method using vectors (or embedding). As described in detail above with respect to FIG. 3, task server 110 or cryptocurrency system/network 150, such as a central cryptocurrency server or compute resource (or node) 210, may perform operation 310 where one or more tasks are proposed to user device 130 over communication network 120, and sensor 140 may perform operation 320 where sensor 140 senses or measures the body activity of user 145. Sensor 140 (or user device 130) may generate data of the body activity in the form of images, waves, signals, numbers, characters, strings or any other form that can represent the body activity.

[0055] At operation 710, user device 130 produces one or more vectors (or embeddings), such as an array of floating point numbers, from the data of the body activity generated by sensor 140 (or user device 130). An algorithm stored in user device 130, or any device, server, system or network communicatively connected to user device 130 over communication network 120, may transform the data of the body activity generated by sensor 140 (or user device 130) into one or more vectors. For example, the brain image generated by the fMRI scanner may be fed into a computer vision machine learning algorithm, for example, but limited to, a convolution neural network, and the machine learning algorithm may generate one or more vectors from one or more voxels of the brain image. In some embodiments, one single vector may be generated at operation 710. In other embodiments, a series of vectors may be produced by sampling over time when user 145 is performing the task(s). The data of the body activity (e.g. voxels of a brain image) and/or the vectors (or embeddings) may generate a “proof of work” and be transmitted to cryptocurrency system/network 150.

[0056] In addition, the vectors may optionally include one or more vectors related to the task(s), for example, but not limited to, search terms that user 145 used or identifier(s) of advertisement that user 145 viewed.

[0057] At operation 720, the vector(s) generated at operation 710 may be converted into an encrypted output by using an encryption algorithm, such as a hashing algorithm or function, as explained above with respect to operation 420 of FIG. 4. For example, the vector(s) can be hashed as bytes with the hashing algorithm, such as Secure Hash Algorithm (SHA)-1, SHA-256, SHA-384, SHA-512, and Message Digest (MD)-5.

[0058] However, operation 720 is optional. In some embodiments, user device 130 can

transmit the vector(s) of the body activity produced at operation 710 to cryptocurrency system 150 without encrypting or hashing them.

[0059] At operation 730, cryptocurrency system 150 receives, from user device 130, the data of the body activity of user 145 (e.g. voxels of a brain image) and/or the vector(s) (or the hash) of the body activity of user 145.

[0060] At operation 740, cryptocurrency system 150 checks if the vector(s) received from user device 130 have one or more mathematical properties set by cryptocurrency system/network 150. For example, cryptocurrency system 150 may determine whether the vector(s) of the body activity have similarity (or relationship) with a legitimate vector (or a baseline vector) set by an algorithm of cryptocurrency system 150. The similarity may be measured or calculated using, for example, but not limited to, a cosine similarity, the Euclidean distance, the Manhattan distance, the Minkowski distance, and the Jaccard similarity. The legitimate vector may be set based on the assumption that the vectors of body activities of people who are performing the same task have a certain degree of similarity. Cryptocurrency system 150, such as a central cryptocurrency server/network or compute resource (or node) 210 of FIG. 2, can decide the legitimate vector and similarity. For example, miners like compute resources (or nodes) 210 of FIG. 2 can share their proof of work including, for example, but not limited to, vectors of body activities, with cryptocurrency network 150, and decide the legitimate vector and similarity by calculating the average of the proof of work (e.g. a centroid or weighted average of the vectors and a standard deviation).

[0061] If the vector(s) received from user device 130 have the mathematical property(ies) set by cryptocurrency system/network 150, cryptocurrency system/network 150 rehashes the data of the body activity, transmitted from user device 130 (Operation 750), and then compares the rehashed output with the vectors (or the hash) received from user device 130 (Operation 760). For example, computer resource (or node) 210 of FIG. 2 may rehash the fMRI voxels, transmitted from user device 130, to a vector, and then compare the rehashed vector with the vector received from user device 130 to check whether the body activity data is generated based on human, not random computer generated data. If determining in operation 740 that the vector(s) received user device 130 do not satisfy the mathematical property(ies) set by cryptocurrency system/network 150 or if determining in operation 760 that the rehashed output does not match the vector(s) (or the hash) received from user device 130, operation 310 or 320 may be proceeded.

[0062] If the rehashed output is identical to the vector(s) (or the hash) received from user

device 130, cryptocurrency system/network 150 awards cryptocurrency to user 145 as described in detail above with respect to operation 350. For example, in the blockchain cryptocurrency system, a miner, such as one of compute resources (or nodes) 210 of FIG. 2, which performed the validation of the body activity data, may add a new block, which includes the data of the body activity, the vector(s) (or the hash) and/or the number of cryptocurrency units assigned to the user's address, to the blockchain, broadcast a new blockchain with the new block around cryptocurrency network 150, and may be rewarded with transaction fees and/or cryptocurrency.

[0063] FIG. 8 illustrates a schematic of an example computer or processing system that may implement any of the systems, methods, and computer program products, such as task server 110, user device 130, cryptocurrency system 150 and compute resources 210, described herein in one embodiment of the present disclosure. The computer system is only one example of a suitable processing system and is not intended to suggest any limitation as to the scope of use or functionality of embodiments of the methodology described herein. The processing system shown may be operational with numerous other general purpose or special purpose computing system environments or configurations. Examples of well-known computing systems, environments, and/or configurations that may be suitable for use with the processing system shown in FIG. 8 may include, but are not limited to, personal computer systems, server computer systems, thin clients, thick clients, handheld or laptop devices, multiprocessor systems, microprocessor-based systems, set top boxes, programmable consumer electronics, network PCs, minicomputer systems, mainframe computer systems, and distributed cloud computing environments that include any of the above systems or devices, and the like.

[0064] The computer system may be described in the general context of computer system executable instructions, such as program modules, being executed by a computer system. Generally, program modules may include routines, programs, objects, components, logic, data structures, and so on that perform particular tasks or implement particular abstract data types. The computer system may be practiced in distributed cloud computing environments where tasks are performed by remote processing devices that are linked through a communications network. In a distributed cloud computing environment, program modules may be located in both local and remote computer system storage media including memory storage devices.

[0065] The components of computer system 800 may include, but are not limited to, one or more processors or processing units 810, system memory 820, and bus 830 that couples various system components including system memory 820 to processor 810. Processor 810 may

include software module 815 that performs the methods described herein. The module 815 may be programmed into the integrated circuits of processor 810, or loaded from memory 820, storage device 840, or network 850 or combinations thereof.

[0066] Bus 830 may represent one or more of any of several types of bus structures, including a memory bus or memory controller, a peripheral bus, an accelerated graphics port, and a processor or local bus using any of a variety of bus architectures. By way of example, and not limitation, such architectures include Industry Standard Architecture (ISA) bus, Micro Channel Architecture (MCA) bus, Enhanced ISA (EISA) bus, Video Electronics Standards Association (VESA) local bus, and Peripheral Component Interconnects (PCI) bus.

[0067] Computer system 800 may include a variety of computer system readable media. Such media may be any available media that is accessible by computer system, and it may include both volatile and non-volatile media, removable and non-removable media.

[0068] System memory 820 can include computer system readable media in the form of volatile memory, such as random access memory (RAM) and/or cache memory or others. Computer system 800 may further include other removable/non-removable volatile/non-volatile computer system storage media. By way of example only, storage device 840 can be provided for reading from and writing to a non-removable, non-volatile magnetic media (e.g., a "hard drive"). Although not shown, a magnetic disk drive for reading from and writing to a removable, non-volatile magnetic disk (e.g., a "floppy disk"), and an optical disk drive for reading from or writing to a removable, non-volatile optical disk such as a CD-ROM, DVD-ROM or other optical media can be provided. In such instances, each can be connected to bus 630 by one or more data media interfaces.

[0069] Computer system 800 may also communicate with one or more external devices 860 such as a keyboard, a pointing device, a display 870, etc; one or more devices that enable a user to interact with computer system; and/or any devices (e.g., network card, modem, etc.) that enable computer system to communicate with one or more other computing devices. Such communication can occur via Input/Output (I/O) interfaces 880.

[0070] Still yet, computer system 800 can communicate with one or more networks 850 such as a local area network (LAN), a general wide area network (WAN), and/or a public network (e.g., the Internet) via network adapter 855. As depicted, network adapter 855 communicates with the other components of computer system via bus 830. It should be understood that although not shown, other hardware and/or software components could be used in conjunction with computer system. Examples include, but are not limited to: microcode, device drivers,

redundant processing units, external disk drive arrays, RAID systems, tape drives, and data archival storage systems, etc.

[0071] As will be appreciated by one skilled in the art, aspects of the present disclosure may be embodied as a system, method or computer program product. Accordingly, aspects of the present disclosure may take the form of an entirely hardware embodiment, an entirely software embodiment (including firmware, resident software, micro-code, etc.) or an embodiment combining software and hardware aspects that may all generally be referred to herein as a "circuit," "module" or "system." Furthermore, aspects of the present disclosure may take the form of a computer program product embodied in one or more computer readable medium(s) having computer readable program code embodied thereon.

[0072] Any combination of one or more computer readable medium(s) may be utilized. The computer readable medium may be a computer readable signal medium or a computer readable storage medium. A computer readable storage medium may be, for example, but not limited to, an electronic, magnetic, optical, electromagnetic, infrared, or semiconductor system, apparatus, or device, or any suitable combination of the foregoing. More specific examples (a non-exhaustive list) of the computer readable storage medium would include the following: a portable computer diskette, a hard disk, a random access memory (RAM), a read-only memory (ROM), an erasable programmable read-only memory (EPROM or Flash memory), a portable compact disc read-only memory (CD-ROM), an optical storage device, a magnetic storage device, or any suitable combination of the foregoing. In the context of this document, a computer readable storage medium may be any tangible medium that can contain, or store a program for use by or in connection with an instruction execution system, apparatus, or device.

[0073] A computer readable signal medium may include a propagated data signal with computer readable program code embodied therein, for example, in baseband or as part of a carrier wave. Such a propagated signal may take any of a variety of forms, including, but not limited to, electro-magnetic, optical, or any suitable combination thereof. A computer readable signal medium may be any computer readable medium that is not a computer readable storage medium and that can communicate, propagate, or transport a program for use by or in connection with an instruction execution system, apparatus, or device.

[0074] Program code embodied on a computer readable medium may be transmitted using any appropriate medium, including but not limited to wireless, wireline, optical fiber cable, RF, etc., or any suitable combination of the foregoing.

[0075] Computer program code for carrying out operations for aspects of the present invention

may be written in any combination of one or more programming languages, including an object oriented programming language such as Java, Smalltalk, C++ or the like and conventional procedural programming languages, such as the "C" programming language or similar programming languages, a scripting language such as Perl, VBS or similar languages, and/or functional languages such as Lisp and ML and logic-oriented languages such as Prolog. The program code may execute entirely on the user's computer, partly on the user's computer, as a stand-alone software package, partly on the user's computer and partly on a remote computer or entirely on the remote computer or server. In the latter scenario, the remote computer may be connected to the user's computer through any type of network, including a local area network (LAN) or a wide area network (WAN), or the connection may be made to an external computer (for example, through the Internet using an Internet Service Provider).

[0076] Aspects of the present disclosure are described with reference to flowchart illustrations and/or block diagrams of methods, apparatus (systems) and computer program products according to some embodiments of the present disclosure. It will be understood that each block of the flowchart illustrations and/or block diagrams, and combinations of blocks in the flowchart illustrations and/or block diagrams, can be implemented by computer program instructions. These computer program instructions may be provided to a processor of a general purpose computer, special purpose computer, or other programmable data processing apparatus to produce a machine, such that the instructions, which execute via the processor of the computer or other programmable data processing apparatus, create means for implementing the functions/acts specified in the flowchart and/or block diagram block or blocks.

[0077] These computer program instructions may also be stored in a computer readable medium that can direct a computer, other programmable data processing apparatus, or other devices to function in a particular manner, such that the instructions stored in the computer readable medium produce an article of manufacture including instructions which implement the function/act specified in the flowchart and/or block diagram block or blocks.

[0078] The computer program instructions may also be loaded onto a computer, other programmable data processing apparatus, or other devices to cause a series of operational steps to be performed on the computer, other programmable apparatus or other devices to produce a computer implemented process such that the instructions which execute on the computer or other programmable apparatus provide processes for implementing the functions/acts specified in the flowchart and/or block diagram block or blocks.

[0079] The flowchart and block diagrams in the figures illustrate the architecture, functionality,

and operation of possible implementations of systems, methods and computer program products according to various embodiments of the present invention. In this regard, each block in the flowchart or block diagrams may represent a module, segment, or portion of code, which comprises one or more executable instructions for implementing the specified logical function(s). It should also be noted that, in some alternative implementations, the functions noted in the block may occur out of the order noted in the figures. For example, two blocks shown in succession may, in fact, be executed substantially concurrently, or the blocks may sometimes be executed in the reverse order, depending upon the functionality involved. It will also be noted that each block of the block diagrams and/or flowchart illustration, and combinations of blocks in the block diagrams and/or flowchart illustration, can be implemented by special purpose hardware-based systems that perform the specified functions or acts, or combinations of special purpose hardware and computer instructions.

[0080] The computer program product may comprise all the respective features enabling the implementation of the methodology described herein, and which - when loaded in a computer system - is able to carry out the methods. Computer program, software program, program, or software, in the present context means any expression, in any language, code or notation, of a set of instructions intended to cause a system having an information processing capability to perform a particular function either directly or after either or both of the following: (a) conversion to another language, code or notation; and/or (b) reproduction in a different material form.

[0081] The terminology used herein is for the purpose of describing particular embodiments only and is not intended to be limiting of the invention. As used herein, the singular forms "a", "an" and "the" are intended to include the plural forms as well, unless the context clearly indicates otherwise. It will be further understood that the terms "comprises" and/or "comprising," when used in this specification, specify the presence of stated features, integers, steps, operations, elements, and/or components, but do not preclude the presence or addition of one or more other features, integers, steps, operations, elements, components, and/or groups thereof.

[0082] The corresponding structures, materials, acts, and equivalents of all means or step plus function elements, if any, in the claims below are intended to include any structure, material, or act for performing the function in combination with other claimed elements as specifically claimed. The description of the present invention has been presented for purposes of illustration and description, but is not intended to be exhaustive or limited to the invention in the form

disclosed. Many modifications and variations will be apparent to those of ordinary skill in the art without departing from the scope and spirit of the invention. The embodiment was chosen and described in order to best explain the principles of the invention and the practical application, and to enable others of ordinary skill in the art to understand the invention for various embodiments with various modifications as are suited to the particular use contemplated.

[0083] Various aspects of the present disclosure may be embodied as a program, software, or computer instructions embodied in a computer or machine usable or readable medium, which causes the computer or machine to perform the steps of the method when executed on the computer, processor, and/or machine. A program storage device readable by a machine, tangibly embodying a program of instructions executable by the machine to perform various functionalities and methods described in the present disclosure is also provided.

[0084] The system and method of the present disclosure may be implemented and run on a general-purpose computer or special-purpose computer system. The terms “computer system” and “computer network” as may be used in the present application may include a variety of combinations of fixed and/or portable computer hardware, software, peripherals, and storage devices. The computer system may include a plurality of individual components that are networked or otherwise linked to perform collaboratively, or may include one or more stand-alone components. The hardware and software components of the computer system of the present application may include and may be included within fixed and portable devices such as desktop, laptop, and/or server. A module may be a component of a device, software, program, or system that implements some “functionality”, which can be embodied as software, hardware, firmware, electronic circuitry, or etc.

[0085] Although specific embodiments of the present invention have been described, it will be understood by those of skill in the art that there are other embodiments that are equivalent to the described embodiments. Accordingly, it is to be understood that the invention is not to be limited by the specific illustrated embodiments, but only by the scope of the appended claims.

CLAIMS

What is claimed is:

1. A cryptocurrency system, comprising:
 - one or more processors; and
 - memory storing executable instructions that, if executed by the one or more processors, configure the cryptocurrency system to:
 - communicate with a device of a user;
 - receive body activity data which is generated based on body activity of the user, wherein the body activity is sensed by a sensor communicatively coupled to or comprised in the device of the user;
 - verify if the body activity data of the user satisfies one or more conditions set by the cryptocurrency system; and
 - award cryptocurrency to the user whose body activity data is verified.
2. The system of claim 1, wherein the body activity sensed by the sensor comprises at least one of body radiation emitted from the user, body fluid flow, a brain wave, pulse rate or body heat radiation.
3. The system of claim 1, wherein the one or more conditions are set based on an amount of human body activity associated with a task which is provided to the device of the user.
4. The system of claim 1, wherein the one or more conditions comprise a condition that the body activity data represents that the user performs a task provided to the device of the user.
5. The system of claim 1, wherein the body activity data is generated using a hash algorithm converting human body activity into an encryption output, and the generated body activity data comprises a hash of the sensed body activity of the user.

6. The system of claim 1, wherein the body activity data comprises one or more vectors produced from the body activity sensed by the sensor.

7. The system of claim 5, wherein the one or more conditions include a condition that the hash of the body activity includes repeated patterns or a mathematical property set by the cryptocurrency system.

8. The system of claim 1, wherein the cryptocurrency system awards the cryptocurrency to the user by generating a block for the awarded cryptocurrency and adding the block to a blockchain stored in the cryptocurrency system.

9. The system of claim 8, wherein the block comprises data comprising:
a task provided to the device of the user;
information on the awarded cryptocurrency;
a hash associated with the body activity; and
a hash of a previous block.

10. The system of claim 3, wherein the task provided to the device of the user comprises a test for verifying if the user of the device is human or not.

11. The system of claim 5, wherein the cryptocurrency system is configured to:
receive, from the device of the user, data of the body activity generated before the hash algorithm is applied and the hash of the body activity;
rehash the data of the body activity; and
compare the rehashed data with the hash of the body activity received from the device of the user to verify the body activity data.

12. A computer-implemented method, comprising:
receiving, by a device of a user coupled to a network, a task over the network;
sensing, by a sensor communicatively coupled to or comprised in the device of the user, body activity of the user;
generating body activity data based on the sensed body activity of the user;

verifying, by a cryptocurrency system communicatively coupled to the device of the user, if the body activity data satisfies one or more conditions set by the cryptocurrency system; and

awarding, by the cryptocurrency system, cryptocurrency to the user whose body activity data is verified.

13. The method of claim 12, wherein the body activity sensed by the sensor comprises at least one of body radiation emitted from the user, body fluid flow, a brain wave, pulse rate or body heat radiation.

14. The method of claim 12, wherein the one or more conditions are set by the cryptocurrency system based on an amount of human body activity associated with the task provided to the device of the user.

15. The method of claim 12, wherein the body activity data is generated using a hash algorithm converting human body activity into an encryption output, and the generated body activity data comprises a hash of the sensed body activity of the user.

16. The method of claim 12, wherein the body activity data comprises one or more vectors produced from the body activity sensed by the sensor.

17. The method of claim 15, further comprising:

receiving, by the cryptocurrency system, from the device of the user, data of the body activity generated before the hash algorithm is applied and the hash of the body activity;

rehashing, by the cryptocurrency system, the data of the body activity; and

comparing, by the cryptocurrency system, the rehashed data with the hash of the body activity received from the device of the user to verify the body activity data.

18. A device, comprising:

one or more processors communicatively coupled to a sensor, the sensor configured to sense body activity of a user; and

memory storing executable instructions that, if executed by the one or more processors, configure the device to:

receive a task;
generate body activity data based on the sensed body activity of the user, wherein the sensed body activity is associated with the received task; and
transmit the generated body activity data to a system or network which verifies the body activity data to award cryptocurrency.

19. The system of claim 18, wherein the body activity sensed by the sensor comprises at least one of body radiation emitted from the user, body fluid flow, a brain wave, pulse rate or body heat radiation.

20. The system of claim 18, wherein the body activity data is generated using a hash algorithm converting human body activity into an encryption output.

ABSTRACT

Human body activity associated with a task provided to a user may be used in a mining process of a cryptocurrency system. A server may provide a task to a device of a user which is communicatively coupled to the server. A sensor communicatively coupled to or comprised in the device of the user may sense body activity of the user. Body activity data may be generated based on the sensed body activity of the user. The cryptocurrency system communicatively coupled to the device of the user may verify if the body activity data satisfies one or more conditions set by the cryptocurrency system, and award cryptocurrency to the user whose body activity data is verified.

<OC Ref/MT Ref 405046-US-NP>

100

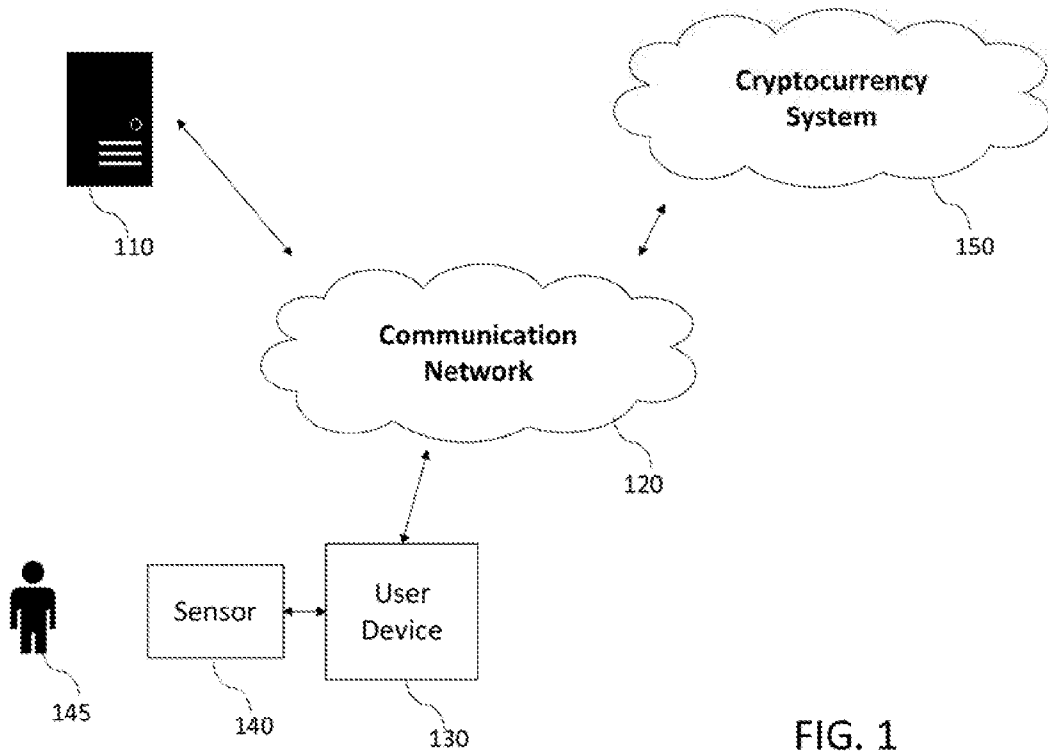

FIG. 1

<OC Ref/MT Ref 405046-US-NP>

200 (150)

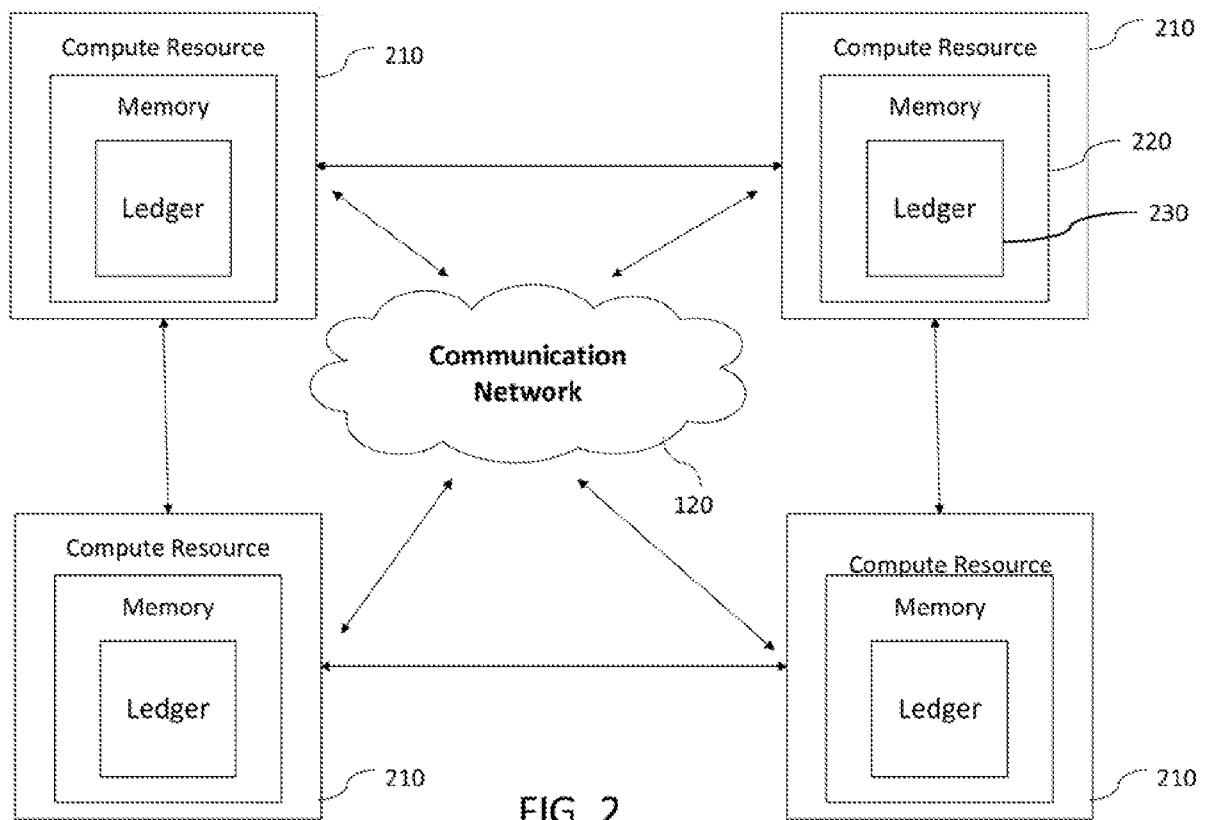

FIG. 2

300

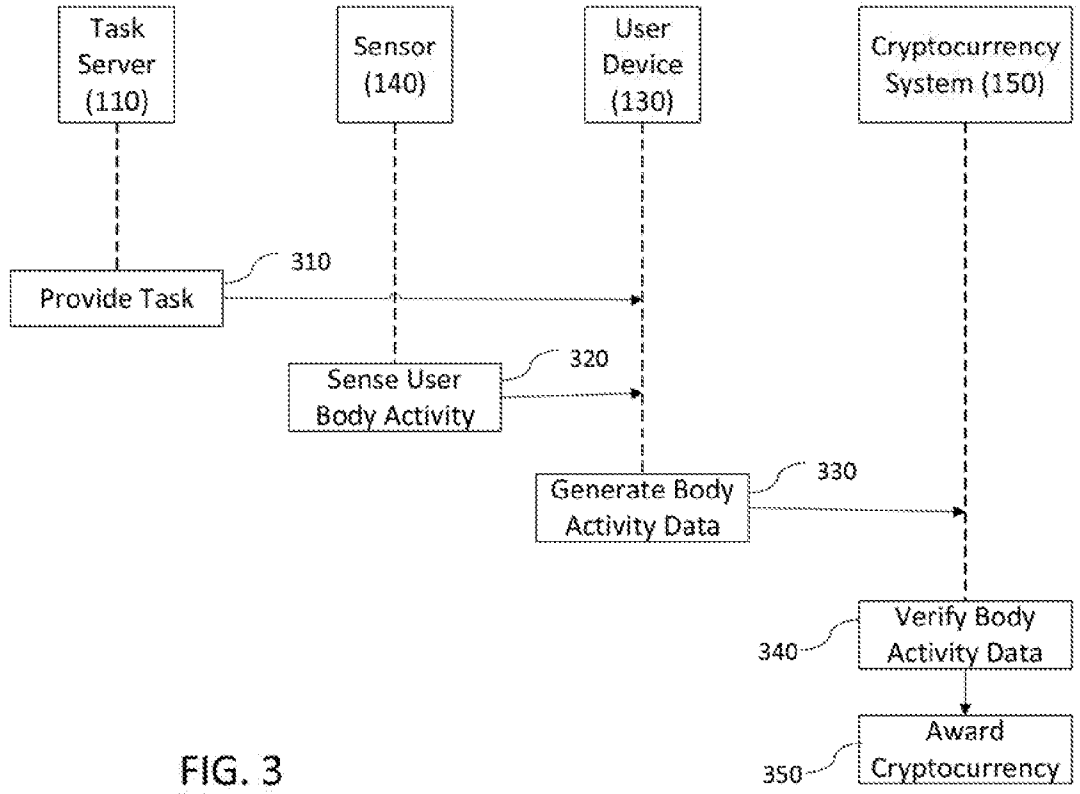

FIG. 3

330

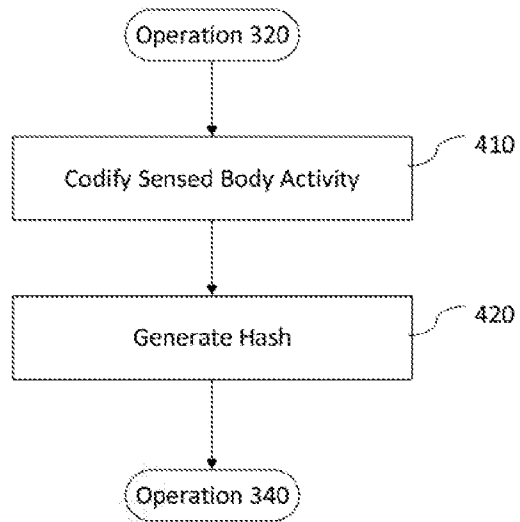

FIG. 4

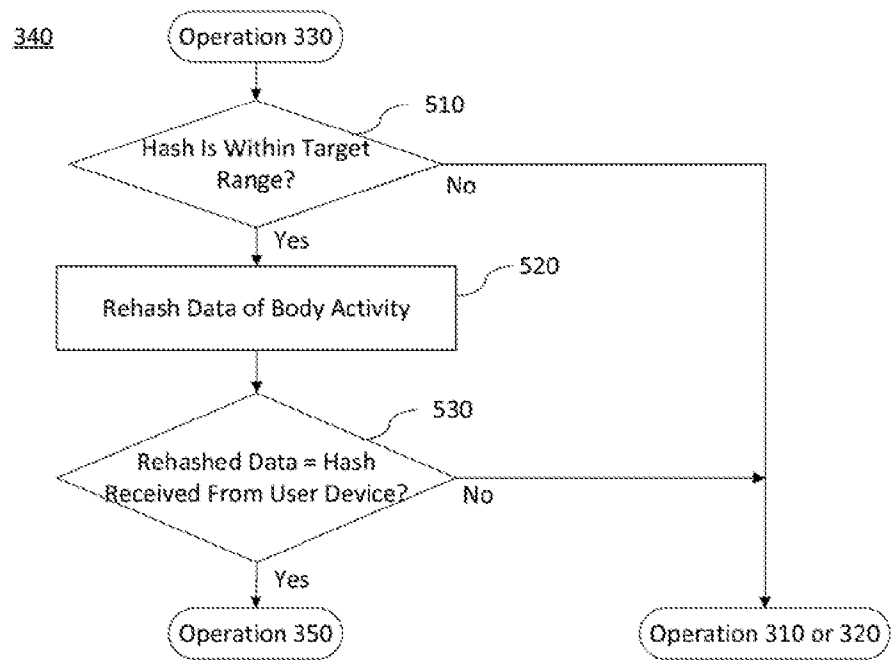

FIG. 5

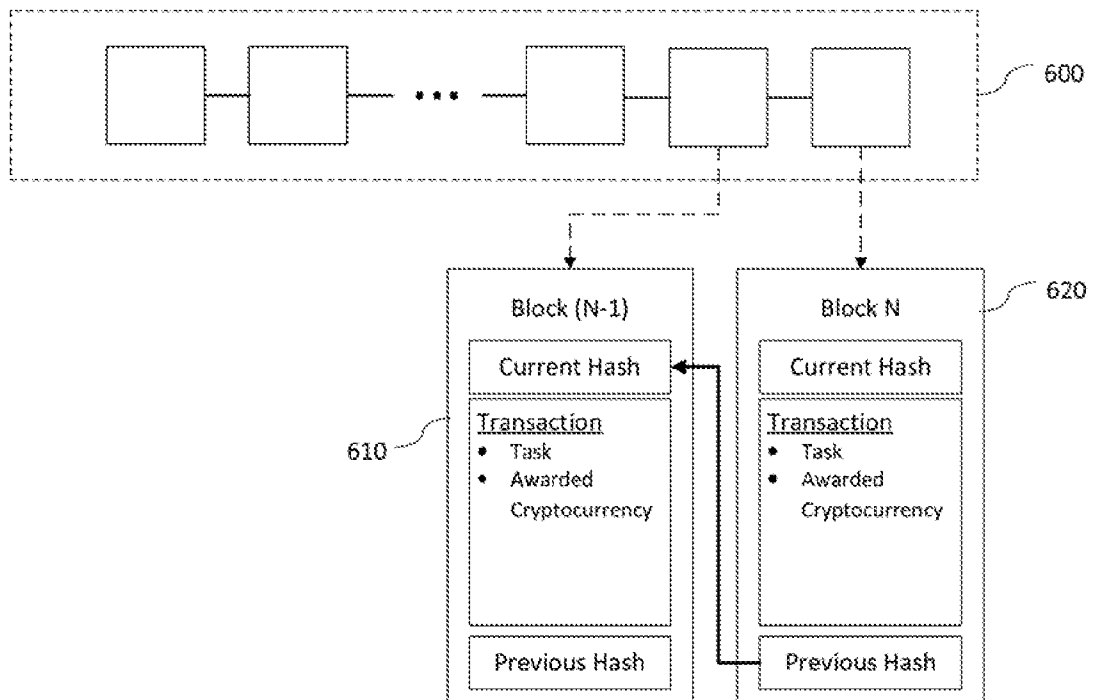

FIG. 6

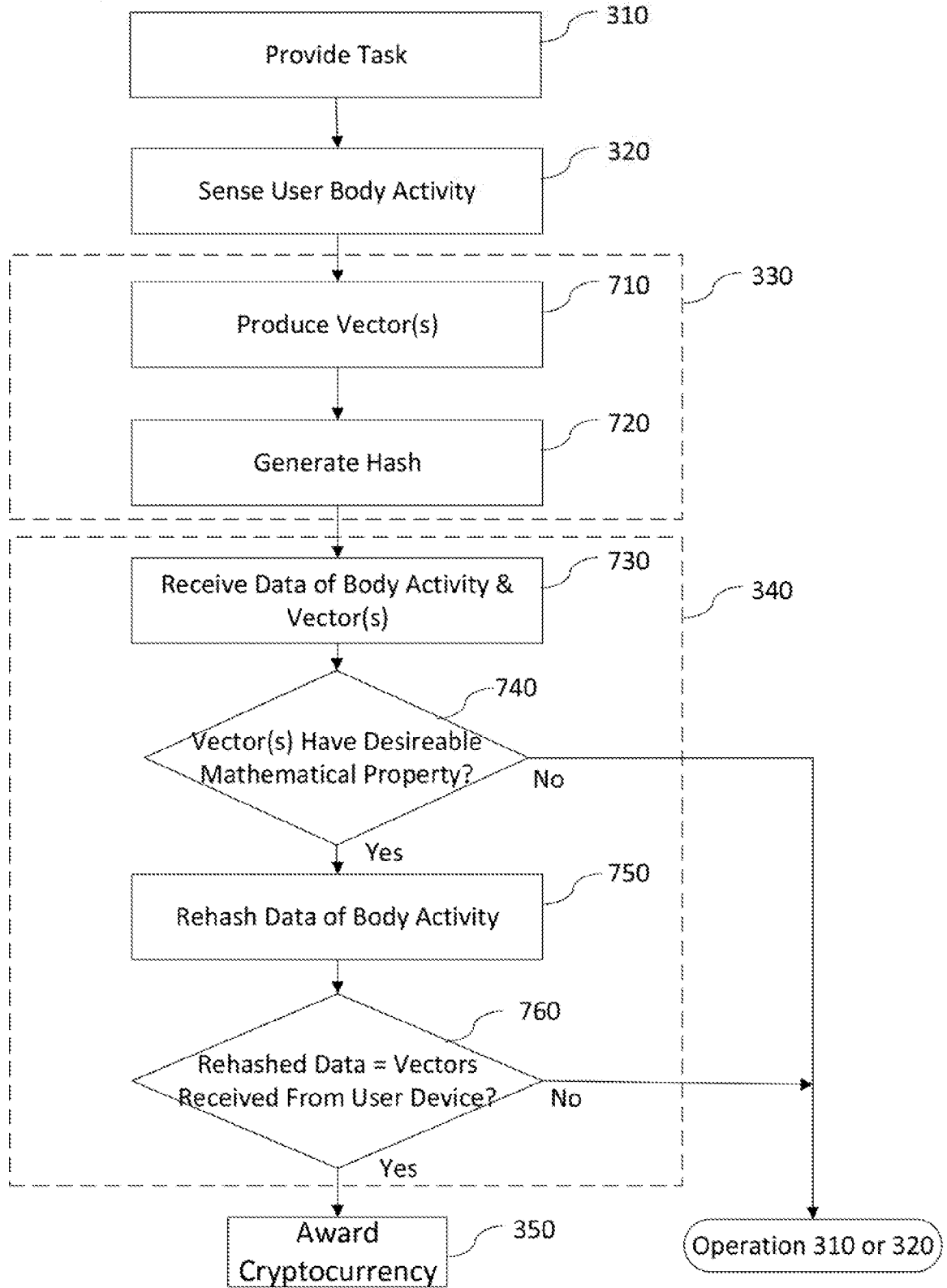

FIG. 7

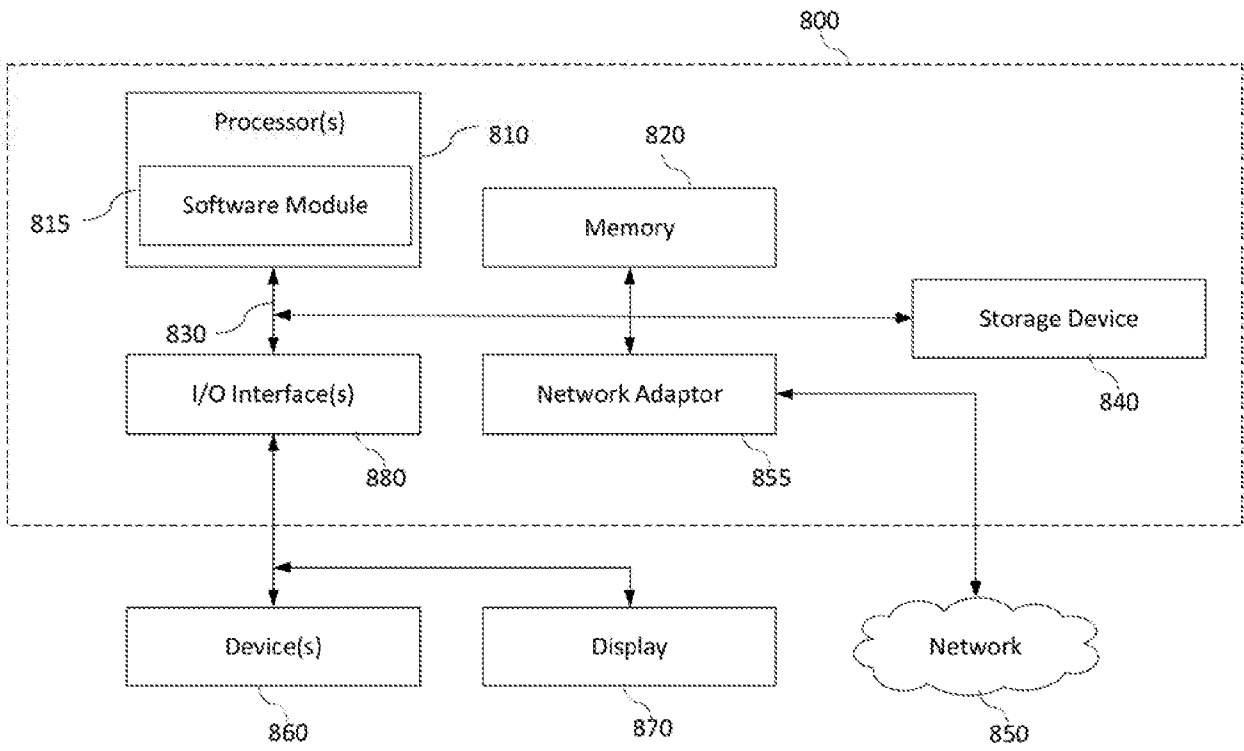

FIG. 8

Under the Paperwork Reduction Act of 1995, no persons are required to respond to a collection of information unless it displays a valid OMB control number.

TRANSMITTAL FOR POWER OF ATTORNEY TO ONE OR MORE REGISTERED PRACTITIONERS

NOTE: This form is to be submitted with the Power of Attorney by Applicant form (PTO/AIA/82B) to identify the application to which the Power of Attorney is directed, in accordance with 37 CFR 1.5, unless the application number and filing date are identified in the Power of Attorney by Applicant form. If neither form PTO/AIA/82A nor form PTO/AIA82B identifies the application to which the Power of Attorney is directed, the Power of Attorney will not be recognized in the application.

Application Number	Not yet assigned
Filing Date	Herewith
First Named Inventor	Dustin ABRAMSON, et al
Title	CRYPTOCURRENCY SYSTEM USING BODY ACTIVE DATA
Art Unit	Not yet assigned
Examiner Name	Not yet assigned
Attorney Docket Number	U 020233-5

SIGNATURE of Applicant or Patent Practitioner

Signature	/Raymond A. Diperna/	Date (Optional)	September 21, 2018
Name	Raymond A. Diperna	Registration Number	44063
Title (if Applicant is a juristic entity)			
Applicant Name (if Applicant is a juristic entity)			

NOTE: This form must be signed in accordance with 37 CFR 1.33. See 37 CFR 1.4(d) for signature requirements and certifications. If more than one applicant, use multiple forms.

*Total of one forms are submitted.

This collection of information is required by 37 CFR 1.131, 1.32, and 1.33. The information is required to obtain or retain a benefit by the public which is to file (and by the USPTO to process) an application. Confidentiality is governed by 35 U.S.C. 122 and 37 CFR 1.11 and 1.14. This collection is estimated to take 3 minutes to complete, including gathering, preparing, and submitting the completed application form to the USPTO. Time will vary depending upon the individual case. Any comments on the amount of time you require to complete this form and/or suggestions for reducing this burden, should be sent to the Chief Information Officer, U.S. Patent and Trademark Office, U.S. Department of Commerce, P.O. Box 1450, Alexandria, VA 22313-1450. DO NOT SEND FEES OR COMPLETED FORMS TO THIS ADDRESS. **SEND TO: Commissioner for Patents, P.O. Box 1450, Alexandria, VA 22313-1450.**

If you need assistance in completing the form, call 1-800-PTO-9199 and select option 2.

POWER OF ATTORNEY BY APPLICANT

I hereby revoke all previous powers of attorney given in the application identified in either the attached transmittal letter or the boxes below.

Application Number	Filing Date

(Note: The boxes above may be left blank if information is provided on form PTO/AIA/82A.)

- I hereby appoint the Patent Practitioner(s) associated with the following Customer Number as my/our attorney(s) or agent(s), and to transact all business in the United States Patent and Trademark Office connected therewith for the application referenced in the attached transmittal letter (form PTO/AIA/82A) or identified above: 156424
- OR
- I hereby appoint Practitioner(s) named in the attached list (form PTO/AIA/82C) as my/our attorney(s) or agent(s), and to transact all business in the United States Patent and Trademark Office connected therewith for the patent application referenced in the attached transmittal letter (form PTO/AIA/82A) or identified above. (Note: Complete form PTO/AIA/82C.)

Please recognize or change the correspondence address for the application identified in the attached transmittal letter or the boxes above to:

- The address associated with the above-mentioned Customer Number
- OR
- The address associated with Customer Number:
- OR

Firm or Individual Name

Address

City	State	Zip	
Country			
Telephone	Email		

I am the Applicant (if the Applicant is a juristic entity, list the Applicant name in the box):

Microsoft Technology Licensing, LLC

- Inventor or Joint Inventor (title not required below)
- Legal Representative of a Deceased or Legally Incapacitated Inventor (title not required below)
- Assignee or Person to Whom the Inventor is Under an Obligation to Assign (provide signer's title if applicant is a juristic entity)
- Person Who Otherwise Shows Sufficient Proprietary Interest (e.g., a petition under 37 CFR 1.46(b)(2) was granted in the application or is concurrently being filed with this document) (provide signer's title if applicant is a juristic entity)

SIGNATURE of Applicant for Patent

The undersigned (whose title is supplied below) is authorized to act on behalf of the applicant (e.g., where the applicant is a juristic entity).

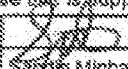
Signature		Date (Optional)	JULY 12, 2018
Name	Suresh Minhas		
Title	President of Microsoft Technology Licensing, LLC		

NOTE: Signature - This form must be signed by the applicant in accordance with 37 CFR 1.33. See 37 CFR 1.4 for signature requirements and certifications. If more than one applicant, use multiple forms.

Total of 1 forms are submitted.

This collection of information is required by 37 CFR 1.131, 1.32, and 1.33. The information is required to obtain or retain a benefit by the public which is to file (and by the USPTO to process) an application. Confidentiality is governed by 35 U.S.C. 422 and 37 CFR 1.11 and 1.14. This collection is estimated to take 3 minutes to complete, including gathering, preparing, and submitting the completed application form to the USPTO. Time will vary depending upon the individual case. Any comments on the amount of time you require to complete this form and/or suggestions for reducing this burden, should be sent to the Chief Information Officer, U.S. Patent and Trademark Office, U.S. Department of Commerce, P.O. Box 1488, Alexandria, VA 22313-1488. DO NOT SEND FEES OR COMPLETED FORMS TO THIS ADDRESS. SEND TO: Commissioner for Patents, P.O. Box 1488, Alexandria, VA 22313-1488.

If you need assistance in completing the form, call 1-800-PTO-9199 and select option 2.

Electronic Acknowledgement Receipt

EFS ID:	33795556
Application Number:	16138518
International Application Number:	
Confirmation Number:	4801
Title of Invention:	CRYPTOCURRENCY SYSTEM USING BODY ACTIVITY DATA
First Named Inventor/Applicant Name:	Dustin ABRAMSON, et al
Customer Number:	156424
Filer:	Janet I. Cord/geraldine marti
Filer Authorized By:	Janet I. Cord
Attorney Docket Number:	U 020233-5
Receipt Date:	21-SEP-2018
Filing Date:	
Time Stamp:	16:57:30
Application Type:	Utility under 35 USC 111(a)

Payment information:

Submitted with Payment	yes
Payment Type	DA
Payment was successfully received in RAM	\$1880
RAM confirmation Number	092418INTEFSW00003514120425
Deposit Account	
Authorized User	

The Director of the USPTO is hereby authorized to charge indicated fees and credit any overpayment as follows:

File Listing:					
Document Number	Document Description	File Name	File Size(Bytes)/ Message Digest	Multi Part /.zip	Pages (if appl.)
1	Transmittal of New Application	020233-5_New_Application_Transmittal.pdf	4292883	no	13
			e347e5e064ae37b19e758002befedbea021f0c7		
Warnings:					
Information:					
2	Application Data Sheet	020233-5_ADS.pdf	1256079	no	9
			688aeec4ef69d93567894a3799c2932310585fab		
Warnings:					
Information:					
3	Specification	020233-5_Specification.pdf	10968701	no	20
			cfac359cf664c648bb216503c809f46d5393e792		
Warnings:					
Information:					
4	Claims	020233-5_Claims.pdf	1031935	no	4
			c8805e09a83e89775c51741b1d32aadd21275d63		
Warnings:					
Information:					
5	Abstract	020233-5_Abstract.pdf	157809	no	1
			485138d3015a7a09a00b2e9f6851d41dd1cd0b77		
Warnings:					
Information:					
6	Drawings-only black and white line drawings	020233-5_Drawings.pdf	578199	no	8
			b4267336e2ffe364fadf68e8761f10d882f7b68		
Warnings:					
Information:					

7	Power of Attorney	020233-5_Transmittal_with_PO A.pdf	452345	no	2
			d52ffe648f6b4f158e4a1e5456e5cea30ced3 9ce		

Warnings:

Information:

8	Fee Worksheet (SB06)	fee-info.pdf	36541	no	2
			6d3bf28ecc70c3be08a4a042714b2428942 de60a		

Warnings:

Information:

Total Files Size (in bytes):	18774492
-------------------------------------	----------

This Acknowledgement Receipt evidences receipt on the noted date by the USPTO of the indicated documents, characterized by the applicant, and including page counts, where applicable. It serves as evidence of receipt similar to a Post Card, as described in MPEP 503.

New Applications Under 35 U.S.C. 111

If a new application is being filed and the application includes the necessary components for a filing date (see 37 CFR 1.53(b)-(d) and MPEP 506), a Filing Receipt (37 CFR 1.54) will be issued in due course and the date shown on this Acknowledgement Receipt will establish the filing date of the application.

National Stage of an International Application under 35 U.S.C. 371

If a timely submission to enter the national stage of an international application is compliant with the conditions of 35 U.S.C. 371 and other applicable requirements a Form PCT/DO/EO/903 indicating acceptance of the application as a national stage submission under 35 U.S.C. 371 will be issued in addition to the Filing Receipt, in due course.

New International Application Filed with the USPTO as a Receiving Office

If a new international application is being filed and the international application includes the necessary components for an international filing date (see PCT Article 11 and MPEP 1810), a Notification of the International Application Number and of the International Filing Date (Form PCT/RO/105) will be issued in due course, subject to prescriptions concerning national security, and the date shown on this Acknowledgement Receipt will establish the international filing date of the application.